

BORRI[®] GALILEO UPS

RT/T UPS 1-3 kVA

User manual

On Line UPS
for ICT, infrastructure and service industry



Index of sections	Code	Page
Safety and storage	OML65003	3
Product introduction	OML65004	6
UPS functional description	OML65005	8
Installation and operating instructions	OML65006	17
UPS Operation under various conditions	OML65007	25
Troubleshooting guide	OML65008	30
Communication software	OML65009	33
Optional battery pack	OML65010	35
Optional communication cards	OML65011	45
Technical specifications	OML65012	49

SAFETY AND STORAGE OF BORRI GALILEO UPS

Index	Page
1 Safety instructions	4
2 Storage instructions.....	5

1 Safety instructions

IMPORTANT: SAFETY INSTRUCTIONS

This manual contains important safety information. Follow these instructions carefully during handling, installation, use and maintenance of the equipment and batteries. Read the product manual carefully before installation. Keep these instructions.

- Inspect the equipment upon receipt and report any damage or malfunction to your dealer. Do not install the equipment if there are signs of damage.
- Use suitable handling devices according to the weight and size of the equipment. Improper handling of loads can create risks for the operator.
- Turn off the equipment and disconnect all electrical power and signalling connections during handling.
- Install the equipment in a closed place protected from dust. The equipment is not intended for outdoor installation. Make sure the place of installation meets the following ambient conditions: temperature: 0-40°C, relative humidity 0-90% non-condensing.
- Do not expose the equipment to direct sunlight, do not obstruct the ventilation ducts on the casing. High ambient temperatures can reduce the life of the batteries and compromise the equipment's operation.
- Do not install the equipment in places where there are flammable or explosive agents.
- Do not install the equipment in places where there are salty or corrosive agents.
- Do not install the equipment in places where there are sparks. During operation, the chemical reactions of battery charging can cause the production of gas. Install the equipment in a ventilated place.
- Vibrations and impacts can compromise the equipment's safety and operation. Locate a protected place for installation.
- Do not place anything on top of the equipment.
- Do not pour liquids in the outer surfaces of the equipment and in the slots in the casing.
- Always disconnect the equipment and check the absence of dangerous potentials before carrying out any maintenance. If the equipment contains energy storage devices, the input and output ports could remain energised even after disconnection.
- Always use protective devices and remove personal items such as bracelets, watches and jewellery before carrying out routine and extraordinary maintenance. Do not remove the protection covers if not required for maintenance.
- Maintenance operations indicated in the product's user manual must be carried out by qualified personnel.
- Repair operations invalidate the warranty. Always contact your dealer or an authorised service centre.
- Make sure the power supply is properly earthed and that the electrical characteristics comply with the rated values required for the equipment.
- Make sure the connection cables comply with the regulations in the country of installation. Do not use worn or damaged connection cables.
- Do not expose the battery cells to flames, overheating of the cells can generate explosions.

- Do not tamper with or modify the battery cells. The electrolyte they contain is toxic to the eyes and skin. Avoid direct contact and inhalation.
- When replacing the battery, use batteries of the same type. Using batteries different from those supplied by the manufacturer can create the risk of fire, explosion and damage to the equipment. For disposal refer, to the local regulations.

2 Storage instructions

If the UPS is unused for an extended period of time it must be stored in a moderate climate. The batteries should be charged for 8 hours every three months by connecting the UPS to the utility supply and switching on the input breaker located on the UPS rear panel. Repeat this procedure every two months if the storage ambient temperature is above 25°C.

PRODUCT INTRODUCTION OF BORRI GALILEO UPS

Index	Page
1 Product introduction.....	7
1.1 General characteristics.....	7
1.2 Special features.....	7

1 Product introduction

1.1 General characteristics

1. True on-line technology continuously supplies your critical device with stable, regulated, transient-free, pure-sine-wave AC power.
2. High-efficiency PWM sine-wave topology yields excellent overall performance.
3. The high crest factor of the inverter handles all high in-rush current loads without the need to upgrade the power rating.
4. User-friendly plug-and-play design allows hassle installation.
5. Built-in maintenance-free, sealed batteries minimize the need for after-sales service.
6. To protect the unit from overloading, the UPS will automatically switch to bypass mode in 30 seconds if loading is at 105% of rated capacity. It will automatically switch back to inverter mode once the overload condition ceases.
7. Should the output become short-circuited the UPS puts the system in stand-by mode, provides visible and audible alarms, and cuts the output supply automatically until the short circuit situation is resolved manually.

1.2 Special features

1. Our High Frequency Transformer-less technology and tower-convertible enclosure enables the UPS to be integrated into even the most difficult environments with space constraints.
2. This UPS is equipped with fully digital control logic for greater functionality and enhanced power protection. Digital signal processing (DSP) also provides the UPS with powerful communication capability, which simplifies remote control and monitoring.
3. Our wide input voltage tolerance of 110-300 V allows under-voltage or over-voltage correction without unnecessary battery drain and helps extend battery life.
4. Our DC-start function ensures the start-up of the UPS even during power outages.
5. Our smart battery management system extends the batteries' life span.
6. Our Active Power Factor Correction control function constantly maintains the UPS input power factor at > 0.98 for superb energy efficiency.
7. Our Selectable Bypass input voltage tolerance (sensitivity low/high) prevents under- or over-voltage being supplied to the loads in Bypass mode. The selectable voltage ranges are (i) Bypass Sensitivity Low: many selectable output voltages $\pm 15\%$ and (ii) Bypass Sensitivity High: many selectable output voltages $\pm 10\%$. For example, if the output voltage setting is 230 V the Bypass Sensitivity Low range is 230 V $\pm 15\%$, i.e., 195.5-264.5 VAC.
8. The UPS provides numerous configurable output voltages to match various system voltages.
9. The UPS is designed to comply with various stringent international standards for electromagnetic interference compatibility (EMC).

PRODUCT INTRODUCTION OF BORRI GALILEO UPS

Index	Page
1 UPS Functional descriptions.....	9
1.1 Front panel display.....	9
1.1.1 Galileo LCD Panel	9
1.1.2 LCD displayer description	10
1.2 Rear panel	11
1.3 Operating modes and system voltage configurations	13
1.3.1 System Configuration Settings	13
1.3.2 Programmable outlet setting.....	14
1.4 Communication port explanation.....	16
1.4.1 True RS-232	16

1 UPS Functional descriptions

1.1 Front panel display









1.1.1 Galileo LCD Panel



Figure 1 Galileo RT



Figure 2 Galileo T

Item	Sign	Description
ON key	 ON	UPS power on switch (Press this key and hold until twice beeps heard to start up UPS).
OFF key	 OFF	UPS power off switch (Press this key and hold until twice beeps heard to shut UPS off).
Select key	 Select	a. Self-test function (When UPS is on, Press this key and hold until twice beeps heard to proceed self-test). b. Display shift of UPS input / output / battery / load / error code information. (Do not hold the key more than 1 second when using function b., function a. could be triggered).
Silence Key	 Silence	Press key to silence UPS while audible alarm.
Normal Mode LED		Lit steady – Utility power normal. Flashing – Utility power low. Dim – Utility power failure/abnormal.
Battery Mode LED		UPS is backing up by battery.
Fault LED		UPS abnormal.
Battery Bad/Weak LED		Battery disconnected, battery voltage low or battery weak/failure.

1.1.2 LCD displayer description

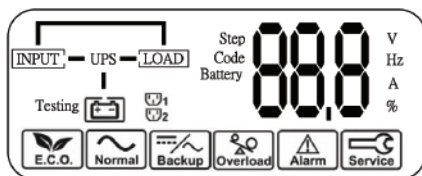

Indication	Sign	Description
Normal Mode		UPS is working with AC input power.
Backup Mode		UPS is backing up with battery.
Overload		UPS is overloading.
Fault		General alarm, UPS fail or other alarm conditions. May appear with error codes.
Maintenance		UPS is working in service or calibration mode.
Programable Outlet status		The sign shows while the specific outlet has output.
Self-testing	Testing	The sign shows while UPS is self-testing.
Text Indicators	Step Code Battery	Read these messages with numeric values Step NN – Service mode steps. Code NN – Error code (shown with general alarm). Battery NN - Battery voltage.
Power Flow Chart		The lines of mimic panel shows the UPS working status.
3 Digit Measurement Display		Numeric information indication.
Units	V Hz A %	Units of measurements display Press key to shift between measurement items.

1.2 Rear panel

GALILEO T

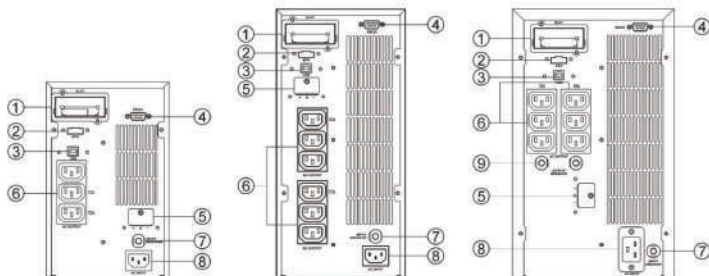

1. Slot for optional communication cards
2. Emergency Power Off (EPO) dry contact signal inputs
3. USB port
4. RS-232 port
5. External battery connector*
6. AC outlets
7. Utility input circuit breaker
8. AC power connection socket
9. Output circuit breaker for two outlets

* Note : This function is optional

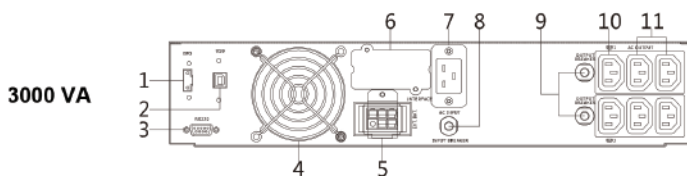
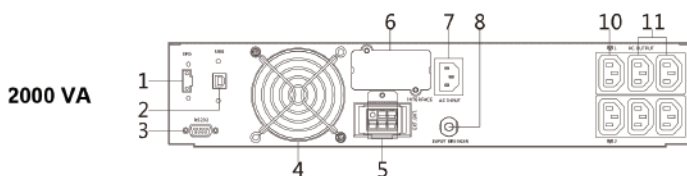
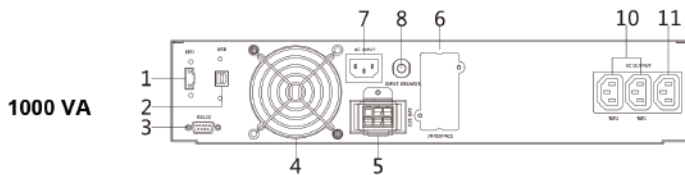
GALILEO RT

1. EPO (Emergency Power Off) connector
2. USB communication port
3. RS-232 communication port
4. Fan
5. External battery connector*
6. Extend communication card slot
7. AC power cord / Inlet
8. AC input breaker
9. Output protecting breaker
10. Programmable power outlets (Program Relay)
11. Power outlets

*Note: Optional function

1.3 Operating modes and system voltage configurations

Download and open the “UPS Setting Tool” software to see the window below.

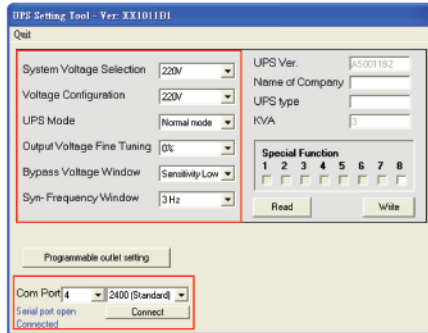

1.3.1 System Configuration Settings

1. System Voltage Selection: Select input voltage 220 V.
2. Voltage Configuration: Select UPS output voltage: 200/208/220/230/240 V.
3. UPS Mode: Select mode: Normal/CF50*/CF60*/ECO mode .
4. Output Voltage Fine Tuning: Output voltage regulation from 0 to $\pm 3\%$
5. Bypass Voltage Window: Sensitivity Low/Sensitivity High

	230 V System Bypass Output
Sensitivity Low	Many Selectable Output Voltages $\pm 15\%$
Sensitivity High	Many Selectable Output Voltages $\pm 10\%$

6. Syn-Frequency Window: Select 3 Hz/1 Hz Inverter Frequency synchronizing range
7. Com Port: Select the COM port of an attached PC.
8. Click on “Write” to confirm the configuration settings. The UPS will beep twice to acknowledge a successful change.
9. Turn off the UPS after changing settings to make sure that the new values are written into EEPROM successfully, then restart the UPS to enable the new settings.

Note:

*CF50/CF60 = Frequency Converter mode 50 to 60 Hz or vice versa

1.3.2 Programmable outlet setting

The UPS is equipped with 2 programmable outlets for use to supply to less critical loads. These outlets can be disabled to shed the less critical loads during back-up modes or overload conditions to maintain quality power supply to the more critical loads connected to the UPS.

Click on the "Programmable outlet setting" bar to enter to the setting screen as shown below.

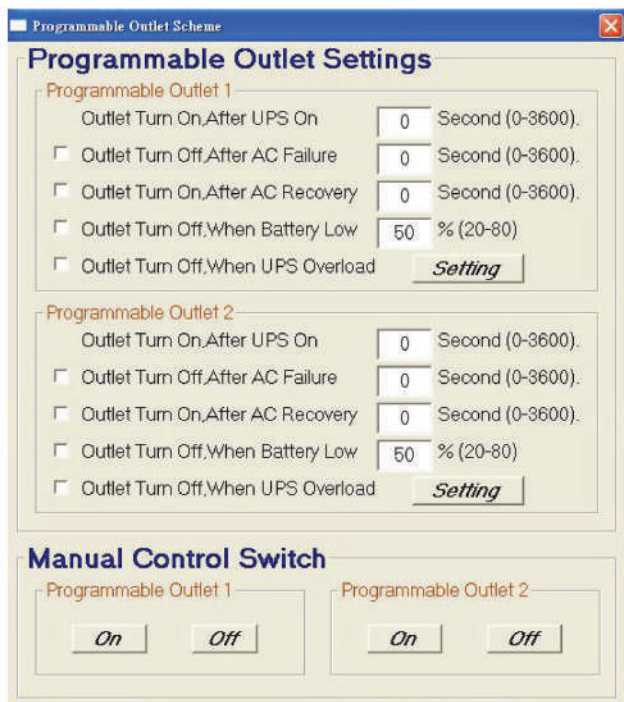

1. Outlet Turn On After Turn on UPS – *select the time to automatically enable this outlet within the specified time when the UPS is powered on. If "0" sec is selected, the outlet will be enabled once the UPS is powered on.*
2. Outlet Turn Off After AC Failure – *select this option to automatically disable the outlet within the specified time after utility outage to shed the less critical loads to provide longer battery back-up time for the other more critical loads connected to the UPS.*
3. Outlet Turn On After AC Recovered – *select this option to automatically enable the outlet within the specified time after the utility is restored.*

4. Outlet Turn Off When Battery Lower than - *select this option to automatically disable the outlet at the specified remaining battery power capacity(%) during battery mode to shed the less critical loads to prolong battery back-up time for the other more critical loads connected to the UPS.*
5. Outlet Turn Off When Overload – *select this option to automatically disable the outlet during overload condition (bypass mode) to possibly allow the more critical loads:*
 - a) *To be continually supplied via Bypass without shut down*
6. You have to select the "Setting" menu to configure new parameters. The calibration is confirmed successfully after the UPS beeps twice. Turn off the UPS and remove the input source to make sure that those new parameters are written into EEPROM successfully, then re-start the UPS to enable the new settings.
7. Manual Control Switch – Click "On" or "Off" to manually enabled or disabled the programmable outlets, overriding all previous settings.

1.4 Communication port explanation

The UPS is equipped with a true RS-232 communication port as standard to provide communication with bundled UPS monitoring software for remote monitoring of the UPS status using a PC.

In addition, there are six optional interface cards available to meet various communication needs: USB, EPO, DCE (dry contact relay card), R2E, USE, and an SNMP/Web card (Please see Chapter OML65011).

The software bundled with the UPS is compatible with many operating systems, including Windows 98 / Me / NT / 2000 / 2003 / XP / Vista / 2008 / 7 / 8 , Novell, NetWare, Unix, Linux 2.6.x, Mac OS X v10.5 Leopard, Mac OS X v10.6 Snow Leopard please contact your local dealer for suitable software.

All communication ports including optional cards can be active and used simultaneously to monitor the UPS status. However, only one communication interface at a time (the one with the highest priority) can control the UPS. The priorities of these communication interfaces are as follows (highest priority first).

- 1) EPO input port
- 2) Interface card
- 3) USB
- 4) RS-232

1.4.1 True RS-232

The RS-232 interface must be configured as follows.

Baud Rate	2400 bps
Data Length	8 bits
Stop Bit	1
Parity	None

Pin Assignments:

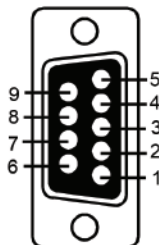

- Pin 3: RS-232 Rx
- Pin 2: RS-232 Tx
- Pin 5: Ground

INSTALLATION AND OPERATING OF BORRI GALILEO UPS

Index	Page
1 Installation and operation	18
1.1 Unpacking	18
1.1.1 Installation Instructions	19
1.2.1 LCD Panel	21
1.2.1.1 Line mode start up	21
1.2.1.2 Cold start (DC start)	22
1.2.1.3 Operation of measurements display	22
1.2.1.4 UPS Locked up	23
1.2.1.5 Turn UPS off	24
1.2.1.6 Self-Test (Line mode only)	24
1.2.2 Beep codes	24

1 INSTALLATION AND OPERATION

Please read the Safety Instruction guide (chapter OML65002) before installing the UPS.

1.1 Unpacking

Inspect the UPS upon receipt. The packaging is robust, but accidents and damage may still occur during shipment. Notify the forwarder and dealer if there is damage.

The packaging is recyclable and reusable.

1. After removing the packing foam please be careful handling the UPS while it is still in the plastic bag. The plastic is slippery, and the UPS could fall and injure your feet.
2. Check for the following standard package contents, in addition to the UPS itself.

A. User Manual

B. IEC output cables (for UPS with IEC sockets only)

C. IEC input cables (for UPS with IEC sockets only)

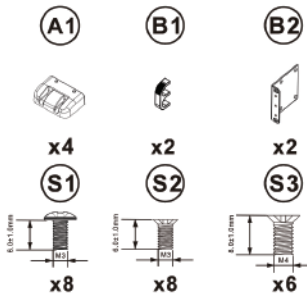

1.1.1 Installation Instructions

Tower installation

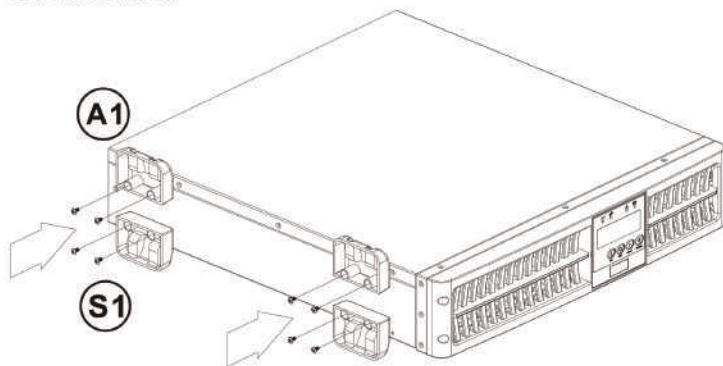

Rack Mount installation

Step 1

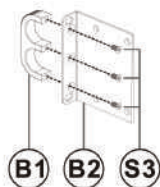

Step 2

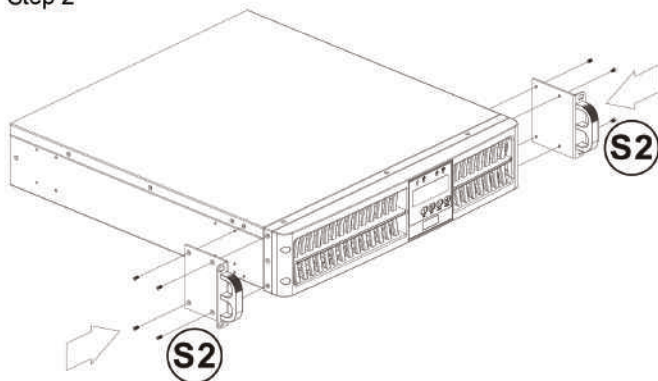

Step 3

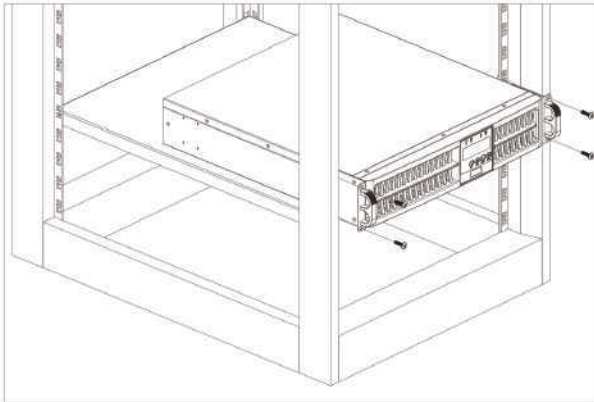
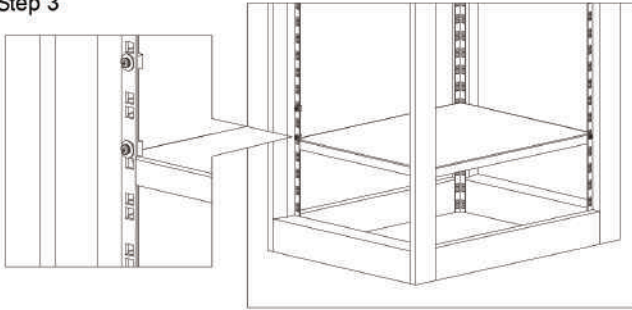

1.2.1 LCD Panel

1.2.1.1 Line mode start up

1. Please ensure the outlet of power source is proper grounded.
2. Ensure the voltage rating of power source is matched with UPS spec.
3. Plug in UPS to the AC source.
4. UPS will start initializing after AC input power is available 5 seconds. LED/LCD indicator will be all lit and dim once and fan will start spinning. Full LCD display looks as below figure:

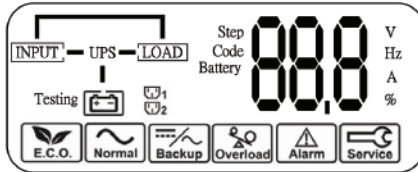

5. Press UPS button and hold until twice beep heard, UPS begins starting procedures for 5 seconds. LCD display will show as below figure-A and then figure-B sequentially. And during the figure-A LCD display, 4 LED "⎓", "🔌", "⚠️", "🔧" will be lit. And then only "⎓" LED remain lit during figure-B LCD display.

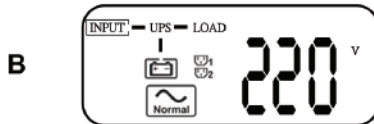
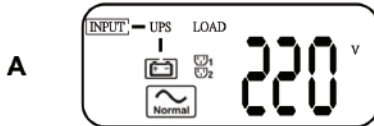

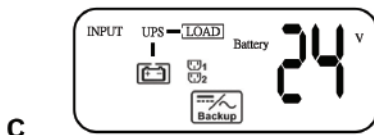

When you see figure-B means the starting up procedure is finished. Please ensure UPS recharge in line mode for at least 4 hours for fully recharged before the first backup test if it's a new installed unit.

6. Back up test – Unplug inlet power cord or switch off power source to simulate power failure condition. Green LED indicator ⎓ will be dimmed and Amber LED 🔌 will be lit. Intermittent audible alarm will be heard and LCD display shows as below figure-C:



1.2.1.2 Cold start (DC start)

1. Ensure the internal battery is available or external battery set well connected to UPS. Press and hold  key for 3 seconds until twice beeps heard, release button and press  for 3 seconds until twice beeps heard again to confirm cold start procedure. If the 2nd button confirmation not be finished within 10 seconds after 1st twice beeps, UPS will not cold start and shut off after 10 seconds.
2. 5 seconds after cold starting, amber LED  will be lit, intermittent audible alarm will be heard and LCD will show sequentially as below figure-D and figure-E

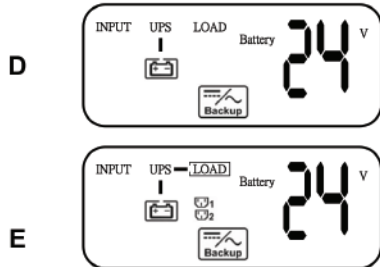

1.2.1.3 Operation of measurements display

1. UPS measurements can be checked after UPS started by pressing select key . The display sequence are as below figure-F (AC input voltage)→figure-G (AC input frequency)→figure-H (UPS output voltage)→figure-I (UPS output frequency)→figure-J (UPS loading percentage)→figure-K (UPS output current)→figure-L (Battery voltage) and back to figure-F.

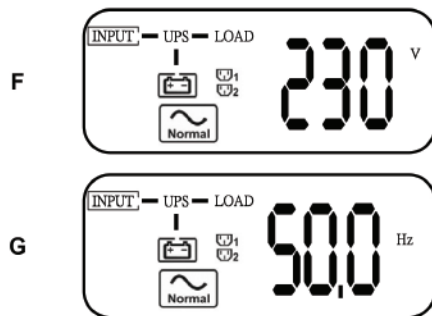

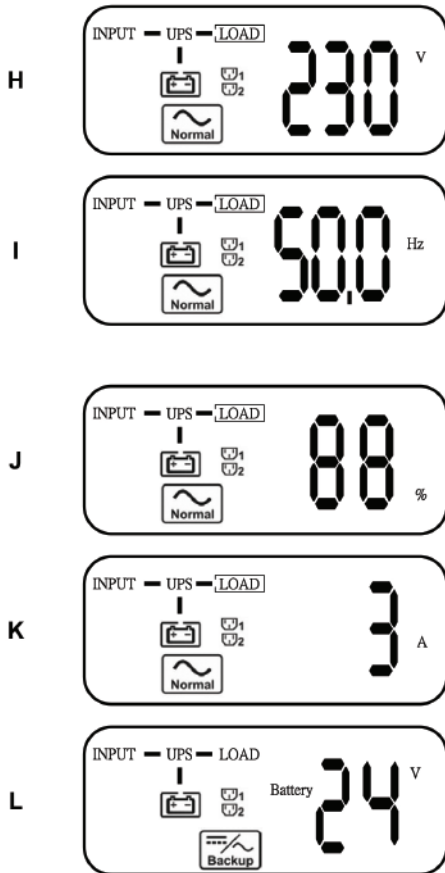

1.2.1.4 UPS Locked up

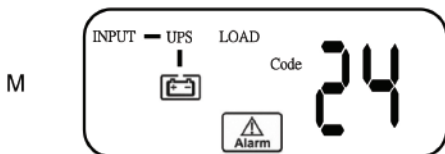

UPS may lock itself up while there was critical abnormal or failure condition happened. User may see LCD display as below figure-M.



The procedures to release UPS from locked up status are as below:





- (a) Check and record the error code.
- (b) Check user's manual to understand possible cause, solve the problem or call service provider.
- (c) Press OFF key  and hold for 5 seconds until twice beep heard.
- (d) Unplug AC input power cord or turn off power source switch.
- (e) After UPS completely shut off, UPS is unlocked.

1.2.1.5 Turn UPS off

1. Line mode(AC input available) : Press Off key  and hold until twice beeps heard, UPS output will shut off. UPS will stay in standby mode, fan(s) keep spinning and battery will be remained recharging if AC input still available after output is off, otherwise it will be shutdown completely.
2. Backup mode (AC input not available): Press Off key  and hold until twice beeps heard, UPS output will shut off. 10 seconds later, fan stop spinning and UPS shutdown completely.

1.2.1.6 Self-Test (Line mode only)

Self-test function can be applied when UPS is working under line mode(AC input available).

Press select key  and hold until twice beeps heard, backup mode LED indicator  will be lit and last for approx 10 seconds and means the UPS is testing backup by battery, and then switch back to line mode normal operation. If there was any failure or battery condition found, LED indicator  and  will be lit and may accompanied with error code.

1.2.2 Beep codes

The following table contains common UPS statuses with their beep codes.

UPS Status	Beep Code
UPS faulty, Inverter shut down. All functions inhibited.	Long Continuous Beep.
Control keypad error	Long Continuous Beep.
UPS faulty, loads continue to be supplied via Inverter or Bypass.	Single beep every two seconds.
In battery mode	Single beep once per second.
Battery low	Quick and short successive beeps.
Confirm RS-232 port receiving	Two quick and short beeps.
Service mode OK	One quick and short beep.

OPERATING UNDER VARIOUS CONDITIONS OF BORRI GALILEO UPS

Index	Page
1 UPS Operation under various conditions	26
1.1 UPS System block diagram.....	26
1.2 When utility is normal	27
1.3 When utility is abnormal or absent.....	27
1.4 Overload condition.....	28
1.5 Inverter failure	29
1.6 Overheating	29
1.7 Inverter current or voltage out of tolerance	29

1 UPS Operation under various conditions

1.1 UPS System block diagram

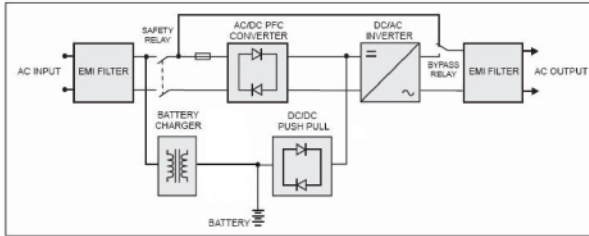

Figure 1

Figure 5.1 illustrates the True On-Line Double Conversion architecture of the UPS system. The major modules consist of:

- 1) An AC-to-DC power converter (rectifier) with PFC control circuit.
- 2) A DC-to-AC high frequency inverter.
- 3) An intelligent battery charger.
- 4) A bank of stationary, maintenance-free batteries.
- 5) A DC-to-DC push/pull converter control circuit.
- 6) A static bypass loop.
- 7) Input and output EMI filters.

The table below provides a summary of the UPS operating modes under various utility AC power source and battery conditions.

Utility Condition	UPS Operating Mode	LEDs
Normal	Working power starts after approximately 5 seconds, LEDs on the panel will blink and fans will start. Press the ON button for 1-5 seconds. The UPS starts up normally.	and Load LEDs remain lit
Abnormal (under or over voltage or absent)	Rectifier and charger stop operating. Battery discharges via DC-DC boost circuit and supplies Inverter. Loads continue to receive supply from Inverter. Alarm buzzer beeps. UPS now in battery mode.	LED off, LED illuminated
Utility abnormal or absent, or battery voltage low	Rectifier and charger stop operating. Battery discharges via DC-DC boost circuit and supplies Inverter. Alarm buzzer beeps quickly, indicating battery power low and Inverter may stop supplying soon.	LED off, and LEDs illuminated

Section 1.2 to 1.7 to this chapter ,below provide detailed descriptions of the UPS operating modes.

1.2 When utility is normal

The operating mode of the UPS under normal utility conditions is illustrated as follows.

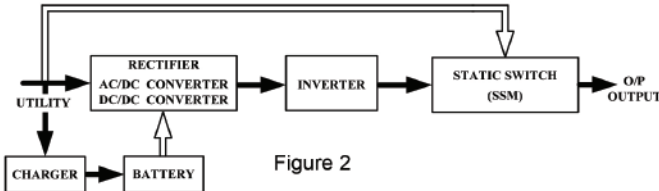

Figure 2

When the utility is normal the AC source is rectified to DC and fed into the charger to charge the batteries and partially fed into the inverter. The inverter reverts the DC to a cleaned and pure AC to supply energy to the load connected. The \sim and Load LEDs shine.

1.3 When utility is abnormal or absent

The operating mode of the UPS under abnormal utility conditions is illustrated as follows.

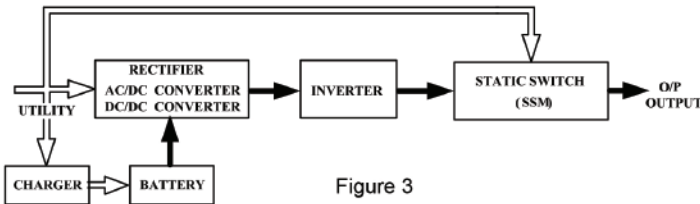

Figure 3

1. When the utility is abnormal the UPS will direct the battery energy automatically to the Inverter without delay and turn off the charger and AC/DC converter. The inverter reverts DC to AC to supply energy to the output load connected without interruption. The \sim LED will shine.
2. When the utility returns to normal the UPS will turn on the AC/DC converter, turn off the DC/DC converter, and switch the charger to charging mode. This is the same operating mode as in Figure 2.
3. During a utility outage the UPS will work as illustrated in Figure 3. When the batteries are low the buzzer will beep continuously until the batteries are completely cut off. The low-battery protection of the UPS will cut off the battery supply at a preset threshold to avoid over-draining the batteries.
4. The UPS will restart automatically when the utility is available, with the same status as in Figure 2.

1.4 Overload condition

The operating mode of the UPS when overloading occurs is illustrated as follows.

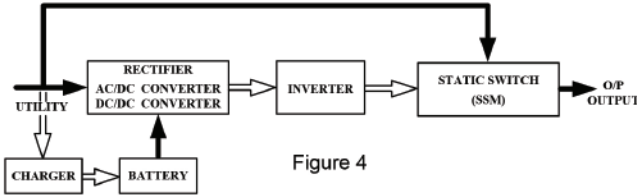
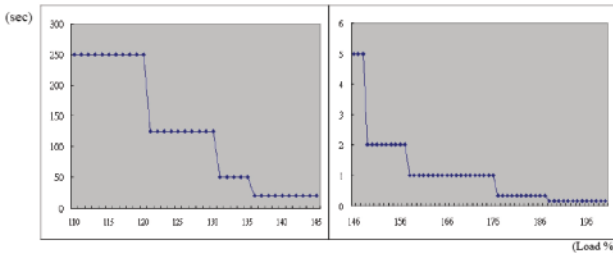

Figure 4

1. Generally, modern electronics and IT equipment generate an inrush current when switching on. The amount of inrush current varies from equipment to equipment, sometimes as high as six times rated capacity, other times negligible. To prevent severe damage to its inverter caused by the inrush produced by the loads, the UPS is equipped with an electronic overload-protection feature as standard. If the UPS is loaded over 150% of capacity it will switch into bypass mode until the load is less than 105%. Then the UPS will switch back to Inverter mode automatically.

2. The UPS Bypass loop is also equipped with overload protection. Its overload capacity is illustrated by the graphs and table below.



Load (%)	110~120	121~130	131~135	136~145	146~148	149~157	158~176	177~187	188<
Delay Time (Sec)	250	125	50	20	5	2	1	0.52	0.16

1.5 Inverter failure

Output load short circuit when supplied via inverter

If the output load is short-circuited while supplied via inverter, the UPS will shut down the inverter automatically and cut the supply to the loads. The Fault LED will shine, and the buzzer will beep continuously. The UPS will not switch on automatically after the short-circuit condition is eliminated. The UPS must be restarted manually.

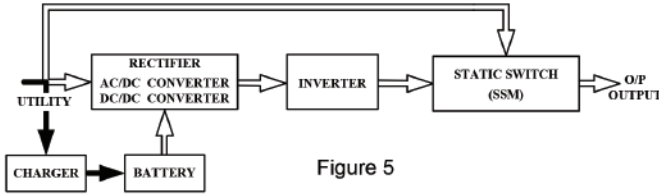

Figure 5

1.6 Overheating

If the UPS overheats when the utility is normal it will switch into bypass mode. The UPS will switch back to inverter mode when the overheating is eliminated. If overheating occurs when the utility is abnormal the buzzer will beep continuously and the Fault LED \triangle will shine. The UPS will cut off supply to the loads.

1.7 Inverter current or voltage out of tolerance

If the UPS inverter delivers over-current or out-of-tolerance voltage to its outlets then the UPS is out of order. The UPS will switch into bypass mode when the utility is normal. The Utility \sim LED, Bypass \sim LED, and Fault \triangle LED will shine.

If these two fault conditions occur when the utility is abnormal the UPS will cut off the supply to its outlets, and the Fault \triangle LED will shine.





TROUBLESHOOTING GUIDE OF BORRI GALILEO UPS

Index	Page
1 Troubleshooting guide.....	31
1.1 Troubleshooting	31
1.2 Error codes and their meanings.....	32
1.3 Maintenance.....	32

1 Troubleshooting guide

1.1 Troubleshooting

If the UPS malfunctions during operation please check that all lines are connected properly and that the utility specifications are correct. Then check the table below for solutions. Should the problem persist please contact your local dealer for assistance.

Situation	Check Items	Solution
Fault  LED Read the error code (see next page) displayed by the combination of LEDs, and verify the fault as follows.	1. Er05, Er24 	1. Check for proper battery connection. Measure battery voltage to ensure that batteries are charged and healthy. Recharge batteries for 8 hours if necessary. Simulate utility outage to verify that UPS is able to provide DC backup. Otherwise consult your local dealer right away.
	2. Overload 	2. Disconnect some non-critical loads from the UPS output until the overload ceases. Check if there is any short circuit between cables due to broken cable insulation. Replace the cables if necessary.
	3. Er11 (UPS Over Temperature)	3. Remove any objects obstructing the ventilation louvers. Verify that the cooling fans are working properly. Contact your local dealer to replace the fans if necessary.
	4. Site wiring/Ground fault 	4. Check if the "L" and "N" phases of the utility AC source have been wrongly wired or if the Ground-Neutral voltage exceeds the limits.
	5. Er14 (Fans out of order)	5. Verify that the ventilating fans are functioning properly. Do not attempt to replace the fans yourself. Contact your local dealer for replacement.
	6. Other error codes	6. Consult your local dealer for assistance.
UPS fails to provide battery backup or its backup time is shorter than its intended performance.		If the backup time remains unsatisfactory after 8 hours of charging please contact your local dealer for battery replacement.
UPS is normal, but there is no output to the load.	Check that all power cords are properly connected.	If the problem persists consult your local dealer for technical assistance.
The UPS switches into battery mode and then back into utility mode when a connected device is turned on, or the UPS switches back and forth between battery and utility modes.	1. A power strip is connected to the UPS. See if there is any damage to the utility wall receptacle or if the cord plug is faulty.	1. Do not use the power strip. 2. Replace the wall receptacle/cord plug.
Strange noise or smell		Immediately shut down the whole system. Disconnect the power from the UPS and call for service.
UPS is unable to provide backup power.		Check that the battery connectors are fully engaged. Allow the batteries to recharge if they are weak. If the problem persists after recharging replace the batteries. If the problem still persists consult your local dealer for technical assistance.

Error Codes

Checking error code on LCD panel

If UPS is in abnormal condition common alarm sign Δ will light up and come with audible alarm. The LCD screen will show information of alternate normal and error code. You can follow section 1.1 and 1.2 up for troubleshooting.

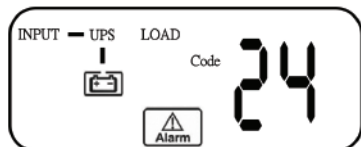

1.2 Error codes and their meanings

Code	Meaning
Er05	Battery weak or faulty
Er06	Output short-circuited
Er07	EPO mode
Er11	UPS over-temperature
Er12	Inverter overload
Er24	Utility low (< 160 V) or battery disconnected
Er28	Bypass overload

1.3 Maintenance

1. Clean the dust from the ventilation openings and intakes on the rear panel.
2. Turn off the UPS and wipe the casing with a damp cloth. Be careful to avoid getting water in the UPS.
3. Periodically unplug the power cord of the UPS from the wall receptacle to test the condition of the batteries. Be sure you have saved your data in any open computer applications before you proceed with this battery test.

COMMUNICATION SOFTWARE OF BORRI GALILEO UPS

Index	Page
1 Communication software	34
1.1 Hardware setup	34
1.2 Software installation	34

1 Communication software

1.1 Hardware setup

1. Decide whether to use RS-232 communication or USB communication.
2. Connect a male RS-232 connector or a USB cable* to the UPS communication port.
Connect the female RS-232 connector or the other end of the USB cable to the computer.

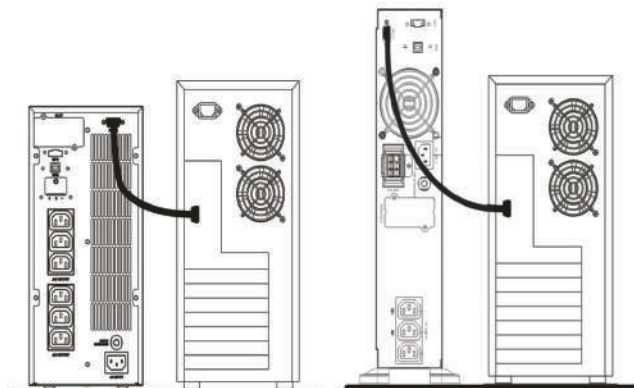

***Note: RS-232 and USB cables are optional.**

1.2 Software installation

Please downloading to www.borri.it

OPTIONAL BATTERY PACK OF BORRI GALILEO UPS

Index	Page
1 Important safety instructions	36
2 Introduction to the rear panel	37
2.1 Real panel T	37
2.2 Real panel RT	38
3 Installation and operation	39
3.1 Unpacking	39
3.1.1 Unpacking GALILEO T	39
3.1.2 unpacking GALILEO RT	39
3.2 Installation instructions	40
3.2.1 Installation instructions GALILEO T	40
3.2.2 Installation instructions GALILEO RT	40
3.2.3 Connect DC cable	42
3.3 Selecting installation position	42
3.3.1 Selecting installation position GALILEO T	42
3.3.2 Selecting installation position GALILEO RT	43
3.4 Storage Instruction	43
3.5 Replacing Battery	43
3.6 External battery box specification	44
3.6.1 External battery box specification GALILEO T	44
3.6.2 External battery box specification GALILEO RT	44
3.7 Cycling the used battery	44

1 Important safety instructions

SAVE THESE INSTRUCTIONS

This manual contains important instructions that should be followed during installation and maintenance of the battery bank and batteries.

An important notice

- The battery bank which is supplied with a factory input plug can be safely connected to the wall receptacle by the user.
- This battery bank is connected to an UPS. There will be voltage at the output terminals if the UPS is turned on even if the input AC Mains is not available.
- Make sure that the AC Utility outlet is correctly grounded.
- Do not try to repair the unit yourself, contact your local supplier or your warranty will be void.
- Use a certified input power cable with the correct plugs and sockets for the appropriate voltage system.
- To eliminate any overheating of the battery bank, keep all ventilation openings free from obstruction and do not place any foreign objects on top of the battery bank. Keep the battery bank 20 cm away from the wall.
- Make sure the battery bank is installed within the proper environment as specified. (0-40°C and 30-90% non-condensing humidity).
- Do not install the battery bank under direct sunlight. Your warranty will be void if the batteries fail due to overheating.
- This battery bank is designed for indoor use only.
- This battery bank is not designed for use in dusty, corrosive and salty environment .
- The warranty for this battery bank will be void if water or other liquid is spilt or poured directly onto the battery bank. Similarly we do not warrant any damage to the battery bank if foreign objects are deliberately or accidentally inserted into the battery bank enclosure.
- The battery will discharge naturally if the system is unused for a period of time.
- It should be recharged every 2-3 months if unused. If this is not done, then the warranty will be null and void. During normal operation, the batteries will be automatically remained in charged condition.
- Servicing of Batteries Should be Performed or Supervised by Trained Personnel with Knowledge of Batteries and the Required Precautions.
- When Replacing Batteries, Replace With the Same Quantity, Type & Capacity.
- CAUTION – Do Not Dispose of Battery or Batteries in an open fire. The Battery May Explode.
- CAUTION – Do not open or mutilate the batteries. The electrolyte from the batteries is toxic and harmful to the skin and eyes.
- CAUTION – Risk of Electric Shock – Battery Circuit is not isolated from AC, hazardous Voltage may exist between battery terminals and ground. Test before touching with bare hands.
- CAUTION – A Battery can present a Risk of Electrical Shock and High Short Circuit Current. The Following Precaution Should be Observed When Working on Batteries:
 - A. Remove watches, rings, or other metal objects.
 - B. Use tools with insulated handles.
 - C. Wear rubber gloves and boots.
 - D. Do not lay tools or metal parts on top of batteries.
 - E. Disconnect charging source prior to connecting or disconnecting battery terminals.

2 Introduction to the rear panel

2.1 Real panel T

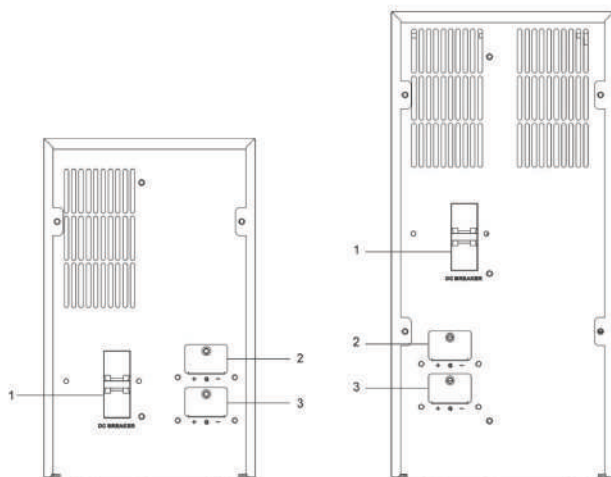

1. DC Breaker	1. Battery Over-current Protection Breaker 2. To easy swappable battery, please put the position of the breaker in "O" position. In case there is 2 nd (or next) battery bank connected with the battery bank, the DC voltage from the UPS Bat.+/- will flow through without any interruption to the 2 nd Battery Bank.
2. UPS BAT. +/-	To the UPS DC Connected.
3. EXT.BAT. +/-	To the DC connected of the 2 nd (or next) battery bank connected.

2.2 Real panel RT

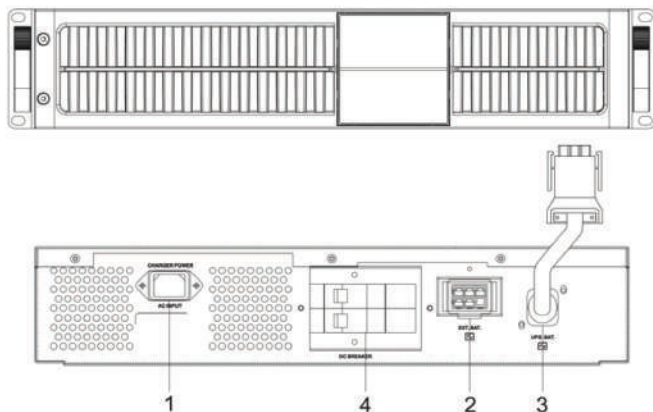

1.AC Connector	Connection AC source if have external charger inside.
2. EXT.BAT. +/-	To the DC terminal of the 2 nd (or next) battery bank connected.
3. UPS BAT. +/-	To the UPS DC terminal or the next battery bank.
4. DC Breaker	1. Battery Over-current Protection Breaker. 2. To easy swappable battery, please put the position of the breaker in "O" position. In case there is 2 nd (or next) battery bank connected with the battery bank, the DC voltage from the UPS Bat.+/- will flow through without any interruption to the 2 nd Battery Bank.

3 Installation and operation

Note: The packing condition and the external outlook of the unit should be inspected carefully before installation. Retain the packing material for future use.

3.1 Unpacking

3.1.1 Unpacking GALILEO T

1. Take the battery bank out of the PE foam.
2. Remove the packing materials.

Note: The battery bank module is approx. 12.2 ~ 38.6kgs, be cautious when unpacking and lifting the unit to avoid injury.

3. Standard Package includes:
 - a. DC connect cable
4. Accessories for Tower Mount

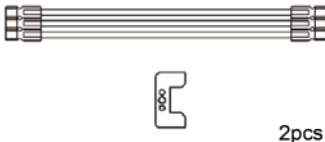
UPS	CONNECTION
BORRI GALILEO UPS 1000 VA BORRI GALILEO UPS 2000 VA BORRI GALILEO UPS 3000 VA	 1pcs 2pcs

3.1.2 unpacking GALILEO RT

1. Take the battery bank out of the PE foam.
2. Remove the packing materials.

Note: The battery bank module is approx. 12.5~50 kgs, be cautious when unpacking and lifting the unit to avoid injury.

3. Accessories for Tower and Rack Mount

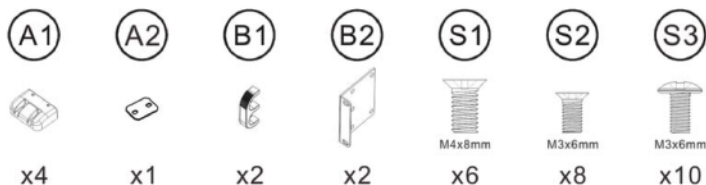

3.2 Installation instructions

3.2.1 Installation instructions GALILEO T

1. For UPS: BORRI GALILEO 1000 VA
BORRI GALILEO 2000 VA
BORRI GALILEO 3000 VA

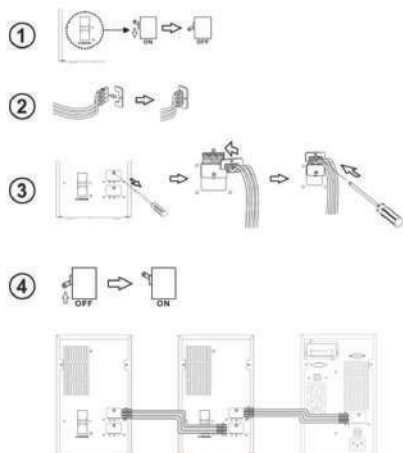

3.2.2 Installation instructions GALILEO RT

3.2.2.1 Stand alone unit

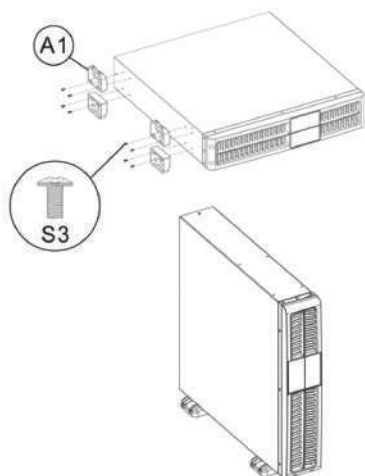

Use with UPS

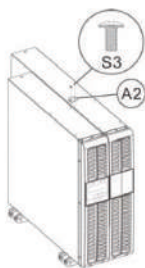

3.2.1.1 Rack mount installation

Step 1

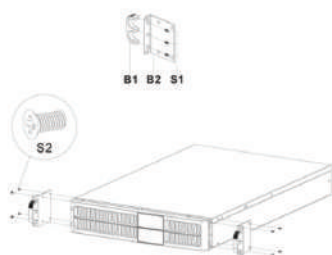

Step 2

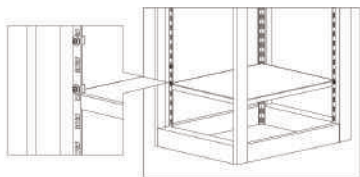

Step 3

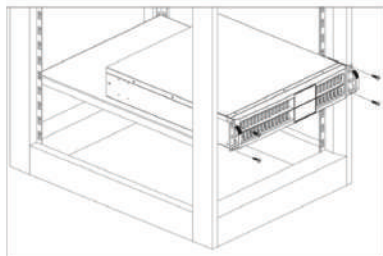

3.2.3 Connect DC cable

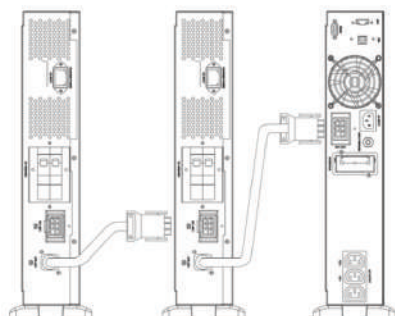

First Battery Bank

Second Battery Bank

UPS

3.3 Selecting installation position

3.3.1 Selecting installation position GALILEO T

It is necessary to select a proper environment to install the unit, in order to minimize the possibility of damage to the battery bank and extend the life of the batteries. Please follow the instructions below:

1. Keep at least 20cm(8 inches) clearance from the rear panel of the battery bank from the wall or other obstructions.
2. Do not block the air-flow to the ventilation openings of the unit.
3. Please ensure the installation site environmental conditions are in accordance with the battery bank working specifications to avoid overheat and excessive moisture.
4. Do not place the battery bank in a dusty or corrosive environment or near any flammable objects.
5. This battery bank is not designed for outdoor use.

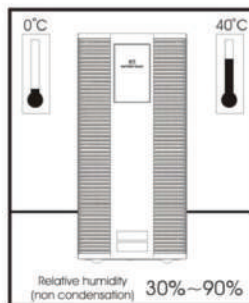
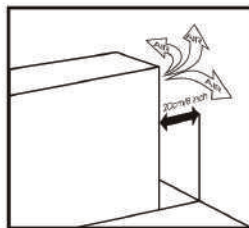

3.3.2 Selecting installation position GALILEO RT

It is necessary to select a proper environment to install the unit, in order to minimize the possibility of damage to the battery bank and extend the life of the batteries. Please follow the instructions below:

1. Keep at least 30cm(12 inches) clearance from the rear panel of the battery bank from the wall or other obstructions.
2. Do not block the air-flow to the ventilation openings of the unit.
3. Please ensure the installation site environmental conditions are in accordance with the battery bank working specifications to avoid overheat and excessive moisture.
Do not place the battery bank in a dusty or corrosive environment or near any flammable objects.
4. This battery bank is not designed for outdoor use.

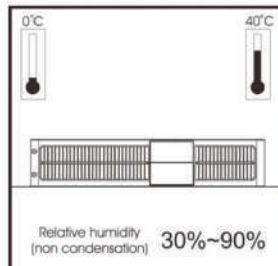
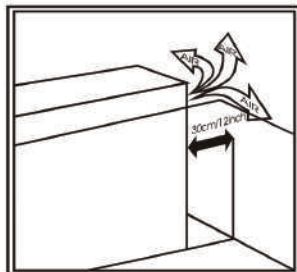

3.4 Storage Instruction

For extended storage through moderate climate(-15 to +30 °C / +5 to +86 °F), the batteries should be charged for 12 hours every 6 months by plugging the UPS power cord into the wall receptacle. Repeat this every 3 months under high temperature (+30 to +45°C/+86 to +113°F) environment.

3.5 Replacing Battery

Step 1



Step 3



Step 5

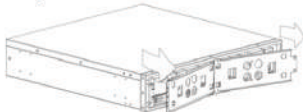

Step 2



Step 4

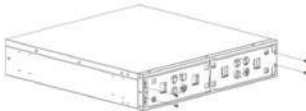

Step 6

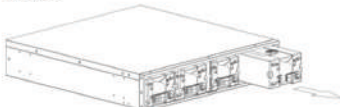

3.6 External battery box specification

3.6.1 External battery box specification GALILEO T

UPS	1000VA	2000VA	3000VA
Battery Bank Code	MUPSBATT0001	MUPSBATT0002	MUPSBATT0003
Nominal System Voltage	24VDC	48VDC	72VDC
Battery Quantity	4	12	12
Battery Type	9Ah	9Ah	9Ah
Max. Charge Current	4.2A	6.3A	4.2A
Connector color	Red(+)Black(!) !. !*~Green(Gnd)		
Dimensions H x W x D (mm)			
Unit	236 x 144 x 367	322 x 151 x 444	322 x 151 x 444
Shipping	527 x 304 x 398	604.6 x 304 x 484	604.6 x 304 x 484
Weight (kg)			
Unit	14.7	39.0	39.0
Shipping	15.9	40.5	40.5

3.6.2 External battery box specification GALILEO RT

UPS	1KVA	2KVA	3KVA
Battery Bank Code	MUPSBATT0006	MUPSBATT0007	MUPSBATT0008
Nominal System Voltage	24VDC	48VDC	72VDC
DC Sockets Diagram			
DC Plug Diagram			

3.7 Cycling the used battery



Contact your local recycling or hazardous waste center for information on proper disposal of the used battery.

OPTIONAL COMMUNICATION CARDS OF BORRI GALILEO UPS

Index	Page
1 Optional communication cards.....	46
1.1 Second RS-232 card.....	46
1.2 USB card	46
1.3 Dry contact card	47
1.4 SNMP cards	48
1.4.1 Megatec SNMP card.....	48
1.4.2 USB	48
1.4.3 EPO	48

1 Optional communication cards

1.1 Second RS-232 card



CN1 is for RS-232 DB9.

For interface settings and pin assignments please refer to Chapter OML65009.

Installation Position: Optional Slot.

1.2 USB card

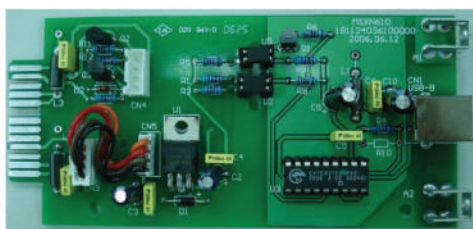

CN1 is for USB.

For the communication protocol definition please refer to Chapter OML65009.

Installation Position: Optional Slot.

1.3 Dry contact card

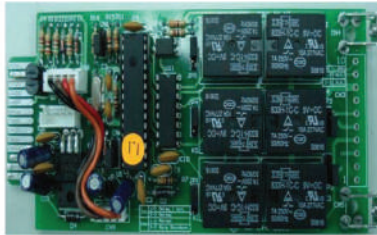

Pin assignments of 10-Pin terminal:

1	2	3	4	4	5	6	7	8	9	10
---	---	---	---	---	---	---	---	---	---	----

- 1 → UPS in Bypass mode (Bypass)
- 2 → Utility Normal (normally closed contact)
- 3 → Utility Normal (normally open contact)
- 4 → Inverter On
- 5 → Battery Low
- 6 → Battery Bad or Abnormal
- 7 → UPS Alarm
- 8 → Common
- 9 → Shutdown UPS positive (+) signal
- 10 → Shutdown UPS negative (-) signal

The shutdown function will be activated after +6-25 VDC is applied between pin 9 and pin 10 for 5 seconds.

The capacity of each relay contact is 40 VDC/25 mA.

Installation Position: Optional Slot.

Flexible signal output for N.C. (Normally Closed) or N.O. (Normally Open) contact by shorting pins 1-2 or pins 2-3 from JP1-5.

The shutdown function will be enabled 1 minute after blackout occurs if pins 1-2 of both CN1 and CN6 are shorted. Otherwise the shutdown function can be enabled only by pins 9-10 of CN3 if pins 2-3 of both CN1 and CN6 are shorted.

1.4 SNMP cards

1.4.1 Megatec SNMP card

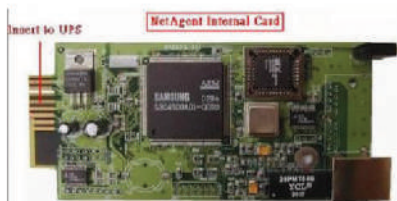

For installation please refer to the user's manual that came with the card.
 Installation Position: Optional slot on rear panel.

1.4.2 USB

The USB communication protocol definition is as below.

1. Complies with USB version 1.0, 1.5 Mbps.
2. Complies with USB HID version 1.0.
3. Pin Assignments:

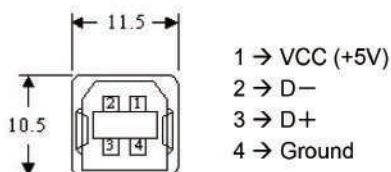

1.4.3 EPO

Pin Assignments:

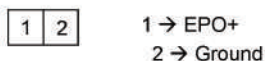

To enable the EPO function short pins 1 and 2.



TECHNICAL SPECIFICATIONS OF BORRI GALILEO UPS

Index	Page
1 Technical specifications.....	50

1 Technical specifications

BORRI GALILEO UPS	T *	T *	T *	RT **	RT **	RT **
Rating (VA)	1000	2000	3000	1000	2000	3000
Nominal power (W)	900	1800	2700	900	1800	2700
UPS dimensions HxWxD (mm)	236x144x367	322x151x444	322x189x444	88x440x390	88x440x475	88x440x600
UPS weight (kg)	10Kg	16,5Kg	22,5Kg	10Kg	18Kg	25Kg
Input						
Nominal voltage (V)	230 Vca single phase					
Voltage range	195 / 260 Vca					
Frequency and range	45 / 65 Hz					
Power factor	0,98					
Current distortion (THDi)	<3%					
Output						
Nominal voltage (V)	230 Vca single phase					
Frequency	50/60 Hz					
Power factor	Any power factor (inductive or capacitive) up to 0.9 without derating					
Overload capability	105% continuous, 106-120% for 30 seconds, 121-150% for 10 seconds, >150% immediately transfer to bypass					
Connectivity and function extensions						
Front panel	Display LCD, LED signaling, function keys					
Communication	Standard: RS232, USB, EPO Opzional: RS485, dry contact card, SNMP card, second RS232 card Compatible platforms: Microsoft Windows, Linux, Mac					
Environmental						
Operating temperature	0°C ÷ +40°C					
Audible noise at 1m	<50 dBA					
Relative Humidity	0-90%					
Standards and certifications						
Marking	CE					
Safety	IEC EN 62040-1					
EMC	IEC EN 62040-2					
Quality assurance, Environment, Health and Safety	ISO9001:2008, ISO 14001:2004, BS OHSAS 18001:2007					

*Tower

**Rack Tower
