

# BORRI<sup>®</sup> LEONARDO UPS

RT/T UPS 6-10 kVA

## User manual

On Line UPS  
for ICT, infrastructure and service industry



---

---

Index of sections	Code	Page
Safety and storage	OML74003	3
Product introduction	OML74004	6
UPS functional description	OML74005	9
Installation and operating instructions	OML74006	15
Troubleshooting guide	OML74007	31
Communication software	OML74008	33
Optional battery pack	OML74009	35
Optional communication cards	OML74010	41
Technical specifications	OML74011	45

---

---

# **SAFETY AND STORAGE OF BORRI LEONARDO UPS**

<b>Index</b>	<b>Page</b>
<b>1 Safety instructions .....</b>	<b>4</b>
<b>2 Storage instructions.....</b>	<b>5</b>

## 1 Safety instructions

### IMPORTANT: SAFETY INSTRUCTIONS

---

This manual contains important safety information. Follow these instructions carefully during handling, installation, use and maintenance of the equipment and batteries. Read the product manual carefully before installation. Keep these instructions.

---

- Inspect the equipment upon receipt and report any damage or malfunction to your dealer. Do not install the equipment if there are signs of damage.
- Use suitable handling devices according to the weight and size of the equipment. Improper handling of loads can create risks for the operator.
- Turn off the equipment and disconnect all electrical power and signalling connections during handling.
- Install the equipment in a closed place protected from dust. The equipment is not intended for outdoor installation. Make sure the place of installation meets the following ambient conditions: temperature: 0-40°C, relative humidity 0-90% non-condensing.
- Do not expose the equipment to direct sunlight, do not obstruct the ventilation ducts on the casing. High ambient temperatures can reduce the life of the batteries and compromise the equipment's operation.
- Do not install the equipment in places where there are flammable or explosive agents.
- Do not install the equipment in places where there are salty or corrosive agents.
- Do not install the equipment in places where there are sparks. During operation, the chemical reactions of battery charging can cause the production of gas. Install the equipment in a ventilated place.
- Vibrations and impacts can compromise the equipment's safety and operation. Locate a protected place for installation.
- Do not place anything on top of the equipment.
- Do not pour liquids in the outer surfaces of the equipment and in the slots in the casing.
- Always disconnect the equipment and check the absence of dangerous potentials before carrying out any maintenance. If the equipment contains energy storage devices, the input and output ports could remain energised even after disconnection.
- Always use protective devices and remove personal items such as bracelets, watches and jewellery before carrying out routine and extraordinary maintenance. Do not remove the protection covers if not required for maintenance.
- Maintenance operations indicated in the product's user manual must be carried out by qualified personnel.
- Repair operations invalidate the warranty. Always contact your dealer or an authorised service centre.
- Make sure the power supply is properly earthed and that the electrical characteristics comply with the rated values required for the equipment.
- Make sure the connection cables comply with the regulations in the country of installation. Do not use worn or damaged connection cables.
- Do not use the equipment to power medical devices whose operation can be hazardous to the patient's health or life.
- Do not expose the battery cells to flames, overheating of the cells can generate explosions.

- Do not tamper with or modify the battery cells. The electrolyte they contain is toxic to the eyes and skin. Avoid direct contact and inhalation.
- When replacing the battery, use batteries of the same type. Using batteries different from those supplied by the manufacturer can create the risk of fire, explosion and damage to the equipment. For disposal refer, to the local regulations.

## **2 Storage instructions**

If the UPS is unused for an extended period of time it must be stored in a moderate climate. The batteries should be charged for 8hours every three months by connecting the UPS to the utility supply and switching on the input breaker located on the UPS rear panel. Repeat this procedure every two months if the storage ambient temperature is above 25°C.



# PRODUCT INTRODUCTION OF BORRI LEONARDO UPS

<b>Index</b>	<b>Page</b>
<b>1 Product introduction.....</b>	<b>7</b>
<b>1.1 General characteristics.....</b>	<b>7</b>

## 1 Product introduction

### 1.1 General characteristics

1. True online architecture continuously supplies your critical device with stable, regulated, transient-free, pure-sine-wave AC power.
2. 20 kHz PWM sine-wave topology yields excellent overall performance. The high crest factor of the inverter handles all high-inrush current loads without a need to upgrade the power rating.
3. The multi-functional LCD/LED panel displays various states of the UPS. The LED display shows the UPS working status, utility status and abnormal status. The LCD display shows input/output voltage, frequency, load status, inner cabinet temperature, and abnormal phenomena.
4. To protect the unit from overloading, it automatically switches to bypass mode in 160 seconds ~ 40ms if loading is at 105 ~150% of rating. In case of overloading at 150% of rating, it switches to bypass mode immediately. It will automatically switch back to inverter mode once the overload condition ceases.
5. Should the output become short-circuited, the UPS cuts the output automatically until the short-circuit situation is removed manually.
6. Should the unit become overheated, the internal thermal switch will detect the heat and switch to bypass mode and vice versa.
7. The fully digitalized control circuit built into the UPS allows upgrading the functionality of the UPS as well as reaching a high-level of protection of the UPS. Powerful communication capability enhances its ability for remote control and monitoring.
8. Maintenance-free, sealed batteries minimize after-sales service.
9. The maintenance bypass switch provides an easy and safe troubleshooting or maintenance function when the utility is normal.
10. Providing four different working modes (Normal, ECO, CF50 and CF60) it may be used in a wide variety of applications.
11. The DC-start function ensures the start-up of the UPS during power outages.
12. A revolutionary battery management circuit analyzes battery discharging status to adjust.
13. The intelligent, temperature-controlled fan may not only extend the life of the fan but also reduce annoying noise because of sudden fan spin. This helps keep your office quiet and comfortable.
14. When the UPS is out of order you can read the possible reason from the LCD screen directly, which reduces unnecessary repairs.
15. When the UPS is operated in CF50 or CF60 mode, the recommended
16. Load connected shall be 75% of rated capacity if the input voltage is 176-280 VAC and 50% of rated capacity if the input voltage is 160-280 VAC.
17. Single input System Block.

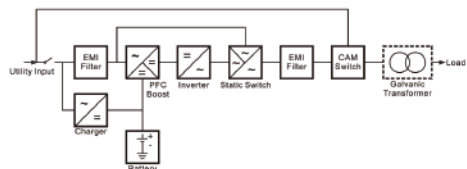

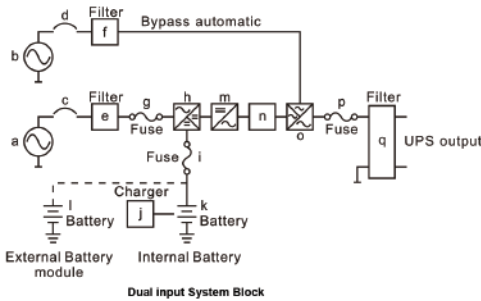

- a. UPS Utility Input: to provide the AC source to the UPS rectifier circuit and charger.
- b. UPS Bypass Input: to provide the AC source to the UPS Bypass Input and Maintenance Bypass loop.
- c. UPS Utility Input Breaker: to protect the UPS Rectifier circuit from over-current.
- d. UPS Bypass Input Breaker: to protect the UPS Bypass circuit from over-current.
- e. EMI Filter on UPS Utility Input : to eliminate the magnetic interference from AC Source or UPS Utility Input.
- f. EMI Filter on UPS Bypass Input: to eliminate the magnetic interference from AC Source or UPS Bypass Input.
- g. Fuse for UPS Utility Input: to provide over-current protection for UPS Rectifier Circuit.
- h. Rectifier and Booster: When Utility is normal, they will converts the AC to DC and correct input power factor. When Utility is abnormal, the batteries will be boosted to provide the DC voltage to the Inverter.
- i. Input fuse for Battery: to protect batteries when DC-Booster is out of order.
- j. Charger: the battery charging device.
- k. Internal Battery: When AC abnormal, it provide the backup power from the batteries.
- l. External Battery Bank: To provide longer backup time by adding additional Battery bank.
- m. Inverter Generator: To convert the DC voltage to AC voltage
- n. Inverter Output Switch: Only when the UPS is overloaded or abnormal, or the UPS is working on ECO mode or if EPO(Emergency Power Off) is activated, the Switch will be opened.
- o. Auto Bypass Loop: When the UPS is overloaded or abnormal, the UPS will Switch the UPS from inverter output to bypass output automatically.
- p. UPS Output Fuse: When the UPS is overloaded, the fuse will open.
- q. UPS Output EMI Filter: To eliminate the magnetic interference from the UPS Output and avoid the interference caused by the output load and the UPS.

## PRODUCT INTRODUCTION OF BORRI LEONARDO UPS

<b>Index</b>	<b>Page</b>
<b>1 UPS Functional descriptions</b> .....	<b>10</b>
<b>1.1 Front panel display</b> .....	<b>10</b>
<b>1.1.1 LEONARDO LCD Panel</b> .....	<b>10</b>
<b>1.1.2 LCD Displayer description</b> .....	<b>11</b>
<b>1.2 Panel explanations</b> .....	<b>13</b>
<b>1.2.1 Rear Panel</b> .....	<b>13</b>
<b>1.3 Communication port explanation</b> .....	<b>13</b>
<b>1.3.1 True RS-232</b> .....	<b>14</b>

## 1 UPS Functional descriptions





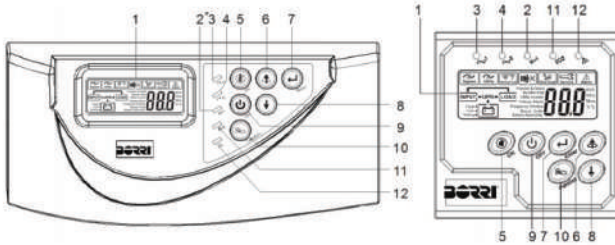











### 1.1 Front panel display



#### 1.1.1 LEONARDO LCD Panel



- 1 LCD
- 2 Green LED indicates that the UPS is able to run under redundancy mode.
- 3 Solid green LED indicates that the utility input voltage is within the window. Flashing green LED indicates that the utility input voltage is outside the acceptable window.
- 4 Green LED indicates that bypass Input is normal.
- 5 UPS ON/Alarm silence.
- 6 Go to previous page or change the setting of the UPS.
- 7 Confirm a changed setting.
- 8 Go to the next page.
- 9 UPS OFF Switch.
- 10 Special functions log in/out.
- 11 UPS is working under ECO (economical) mode.
- 12 UPS fault or abnormal.

## 1.1.2 LCD Displayer description

Item	Symbol	Description
1	INPUT	Utility or Bypass Source
2	Low ◀	Battery low
3	Fault ◀	Battery abnormal
4		UPS overloading
5		UPS working in specified mode*
6		Bypass Input Abnormal, UPS fails to transfer to bypass, bypass Abnormal at ECO mode
7		Utility input abnormal
8	OFF	UPS shutoff
9	INPUT OFF	UPS abnormal Lock
10		UPS flow chart
11		3-digit measurement display
12		Indicates the item to be measured
13		UPS ON switch or alarm silence
14		UPS OFF switch
15		Previous page or setting change
16		Next page
17		Special function log In/Out
18		Enter or reconfirm
19		Utility input normal LED
20		Bypass Input normal LED
21		UPS under redundancy mode

Item	Symbol	Description
22		UPS under ECO mode
23		UPS fault or abnormal warning LED
24	EPO	Emergency power off
25	Er05	Battery weak or dead
26	Er06	Output short circuit
27	Er10	Inverter over-current
28	Er11	The UPS is overheated.
29	Er12	UPS output overloading
30	Er14	Fan error
31	Er15	Wrong procedure to enter maintenance mode
32	Er16	Output parameters set error in parallel system
33	Er17	ID numbers are in conflict in parallel system or ID number error in single unit
34	Er21	Parallel communication error (communication wire disconnected or failure) to find ID1 UPS) in
35	Er24	CVCF mode with bypass input
36	Er27	The UPS must be operated in normal mode in parallel system.
37	Er28	Bypass overload time out and cut off output
38	Er31	Control board and driver board settings do not match.
39	Er33	Isolated transformer is overheated.
40	Er**	Other error code

*\*The specified modes include Normal mode, ECO mode, CVCF mode, etc..*

## 1.2 Panel explanations

### 1.2.1 Rear Panel

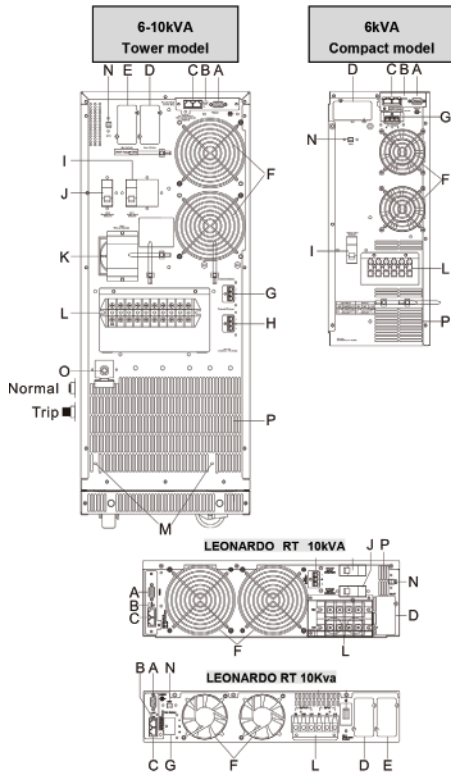

- A RS-232 Port
- B Terminal resistor for parallel function
- C CAN bus connection port for parallel system
- D Customer options slot 1
- E Customer options slot 2
- F Cooling fan
- G External battery connector
- H External charger connector
- I Utility input breaker CB1
- J Bypass input breaker CB2 (for dual input model only)
- K CAM switch (maintenance bypass switch)
- L Input/Output terminal block
- M Mounting holes for external charger cabinet
- N EPO:Emergency Power Off
- O Thermal breaker for the protection of load in abnormal condition: CB3
- P Air ventilation hole

### 1.3 Communication port explanation

The communication port on the UPS provides for RS-232 communication with the UPS software to remotely monitor the power and UPS status.

You may use optional interfaces cards for R2E (second RS-232), RSE (RS-485), USE (USB), DCE (Dry Contact), and SNMP. However, the R2E card, RSE card and USE card must not be used simultaneously.

The software bundled with the UPS is compatible with many operating systems such as Windows 98, 2000, ME, NT and XP. For other applications such as Novell NetWare, Unix, or Linux please contact your local distributor for a proper solution.

When the optional interface cards are used together with the onboard RS-232 port the EPO signals will get highest priority, then the SNMP/WEB card, then the shutdown command at the DCE, R2E, RSE, and USE cards, and then finally the onboard RS-232 port gets the lowest priority.

### 1.3.1 True RS-232

#### Interface Settings

The RS-232 interface shall be set as follows:

<b>Baud Rate</b>	<b>2400 bps</b>
<b>Data Length</b>	<b>8 bits</b>
<b>Stop Bit</b>	<b>1 bit</b>
<b>Parity</b>	<b>None</b>

#### Pin Assignments

The Pin Assignments of true RS-232 are as follows (The connector is male.):

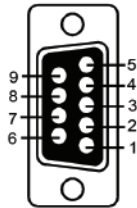

Pin 3: RS-232 Rx

Pin 2: RS-232 Tx

Pin 5: Ground

## INSTALLATION AND OPERATING OF BORRI LEONARDO UPS

<b>Index</b>	<b>Page</b>
<b>1 Installation and operation.....</b>	<b>16</b>
<b>1.2 Unpacking.....</b>	<b>16</b>
<b>1.3 Selecting installation position.....</b>	<b>17</b>
<b>1.4 Installation of the accessories kit.....</b>	<b>17</b>
<b>1.5 Terminal block explanation .....</b>	<b>18</b>
<b>1.6 Installation and operation.....</b>	<b>21</b>
<b>1.6.1 Start Up in normal mode .....</b>	<b>21</b>
<b>1.6.2 Start-up in battery mode (cold start) .....</b>	<b>23</b>
<b>1.6.3 Check measured values and figures detected by the UPS.....</b>	<b>23</b>
<b>1.6.4 UPS default data and special function execution .....</b>	<b>25</b>
<b>1.6.5 UPS Default settings and their alternatives .....</b>	<b>29</b>
<b>1.6.6 Troubleshooting when the UPS is Off Due to unknown reasons .....</b>	<b>30</b>
<b>1.6.7 Shut Off.....</b>	<b>30</b>
<b>1.6.8 Maintenance bypass mode.....</b>	<b>30</b>

# 1 Installation and operation

Carefully inspect the UPS for shipping damage before installation. Retain the packing material for future use.

## 1.2 Unpacking

Standard package contents:

### User Manual

Metal Accessories Kit for Tower model or RT model as below:

Package for the UPS with isolation transformer and dual input:

**Ditto, but with additional 3 pcs wire**

Package for the UPS without isolation transformer but dual input:

**Ditto, but with additional 1 pc wire (p.s. Wire is to be used at the input/output terminal block of the UPS. Please refer to Chapter 1.4 of this chapter for installation.**

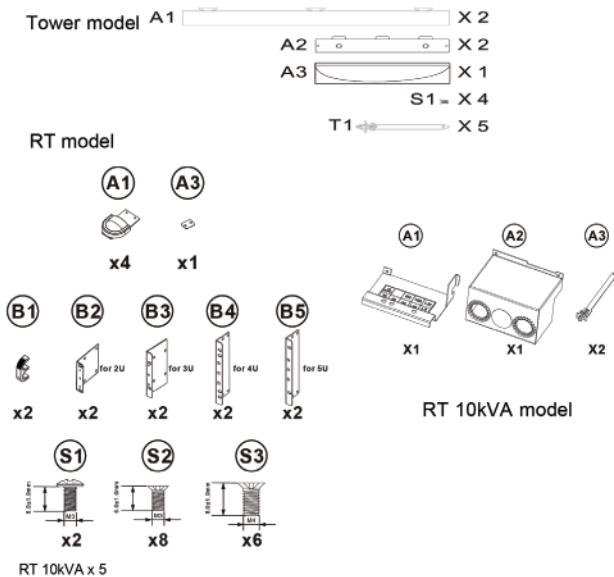

### 1.3 Selecting installation position

Install the UPS in a proper environment to minimize the possibility of damage to the UPS and to extend the life of the UPS. Please follow these rules:

1. Keep at least 30 cm (12 inches) clearance from the rear panel of the UPS to the wall.
2. Do not block the air flow to the ventilation openings of the unit.
3. Ensure that the installation site is not excessively hot or moist.
4. Do not place the UPS in an environment near dust, corrosive or salty material, or flammable objects.
5. Do not expose the UPS to the outdoors.

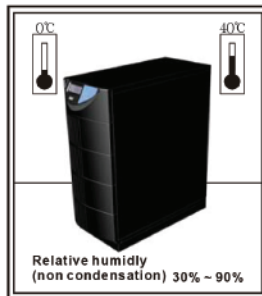
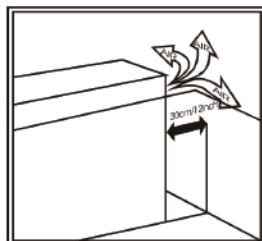

### 1.4 Installation of the accessories kit

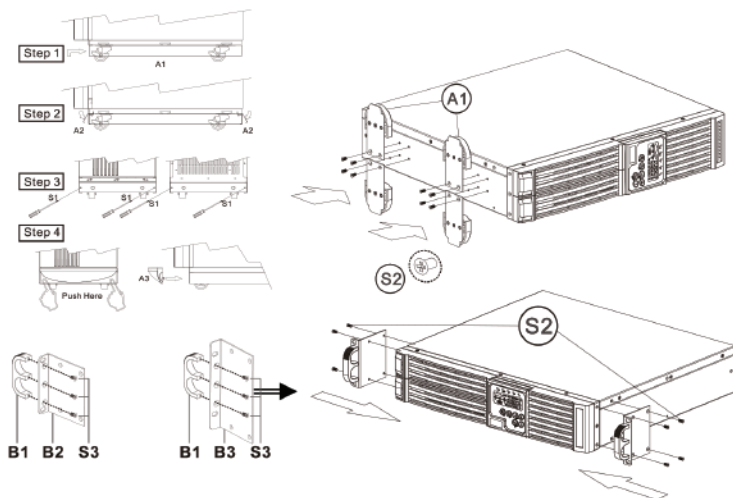

## 1.5 Terminal block explanation

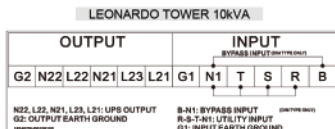
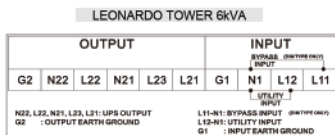

**LEONARDO RACK TOWER 6kVA**

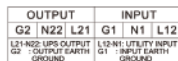

**LEONARDO RACK TOWER 10kVA**

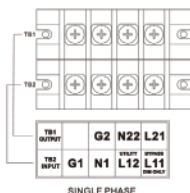

- **L11-N1, B-N1**: the terminal for Bypass Input to provide the power source when the UPS is working under bypass mode.
- **L12-N1, R-S-T-N1**: the terminal for Utility Input to provide the power source when the UPS is working under Utility mode.
- **G1**: the terminal for UPS Input Ground.
- **L21, L23, N21, L22, N22**: the terminals for UPS Output.
- **G2**: the terminal for UPS Output Ground.

### Remarks:

1. The maximum current for each terminal is 30 Arms for 6 kVA, 50 Arms for 10 kVA
2. If the UPS is a DIM (Dual Input) type whose Utility and Bypass Sources are the same, L11 and L12 must be shorted for the 1-phase input.
3. If the UPS is a SIM (Single Input) type, only AC source can be supplied to the UPS from the L12-N1 terminal.
4. When the isolation transformer is not installed into the tower-type UPS the UPS output terminals will be L22-N22.
5. Use No. 6 AWG, 75°C minimum copper wire and 23 lb-in Torque force when connecting to terminal block.

6. When the isolation transformer is installed into the tower-type UPS:  
 a. For 100/110/115/120 VAC systems you may connect as shown below.

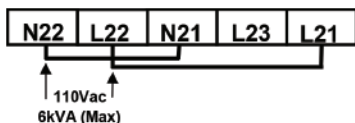

- b. For 200/100 VAC, 220/110 VAC, 230/115 VAC, 240/120 VAC, or 240/208/120 VAC systems you may connect as shown below.

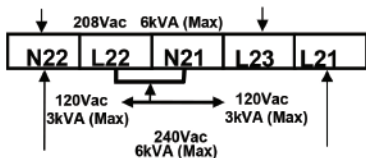

- Use mounting cable ties to fix cables.

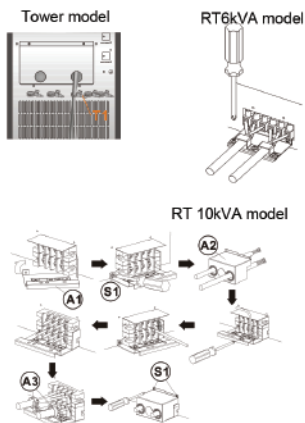

6. Please refer to the specifications of input current, output current and recommended conductors listed below.

- a. AC input and output (minimum 75°C copper wire)

Model	Maximum Current	Conductor Section	Torque force
6 kVA	33 A	AWG #8	17.7/11 lb-in
10 kVA	54.3 A	AWG #6	23 lb-in

b. Battery input

Model	Maximum Current	Conductor Section
6 kVA	25 A	AWG # 10
10 kVA	41 A	AWG # 10

Wiring of UPS module, Transformer module and Battery module

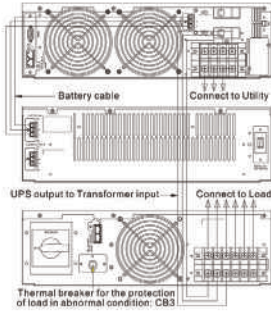

Wiring of UPS module, Transformer module and Battery module

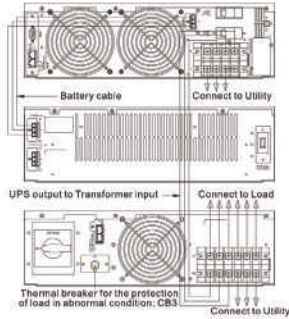

Wiring of UPS module and Battery module  
Connect to Load

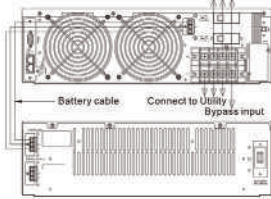

Wiring of UPS module and Battery module  
Connect to Load

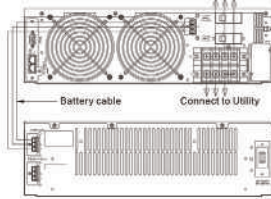

## 1.6 Installation and operation

### 1.6.1 Start Up in normal mode

Open the terminal block cover on the rear panel. (Refer to "Chapter Product Introduction")

Before starting the installation make sure the grounding is connected properly.

Make sure the utility breaker and the UPS' Utility breaker and Bypass breaker are in the "Off" position.

Make sure the utility voltage matches the input voltage window of the UPS.

Connect the utility separately to the terminal blocks of the UPS' Utility and Bypass inputs. Switch on the power breaker of the distribution panel and the breakers of the UPS' Utility and Bypass inputs. Then the UPS will start up. Green LEDs  $\sim 1$  and  $\sim 2$  show that the Utility and Bypass inputs are normal. UPSs with parallel function enabled will display first figure A1, then figure A2, and then figure B. Otherwise the LCD will display figure A1 directly followed by figure B.

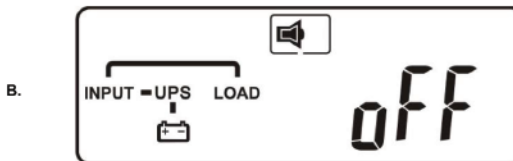
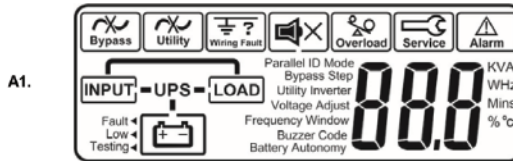

The UPS is in Bypass Mode now. It will proceed to self-test automatically. If no abnormal message appears then the pre-startup of the UPS was successful and the charger starts to charge the batteries.

Press the UPS On Switch (4) for approximately three seconds. The Buzzer sounds twice and the LCD display changes from figure B to figure C.

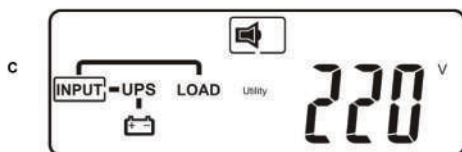

The UPS is in self-test mode again. The LCD display will change from figure C to figure D, and the UPS will remain in battery mode for approximately four seconds. Then the display will change from figure E1 to figure F if the self-test was successful.

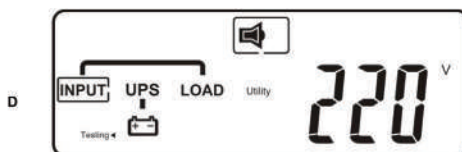

"test"

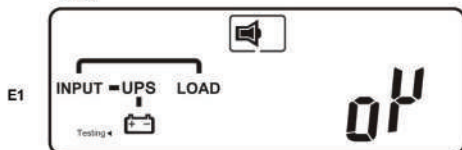

"OK" in self-test

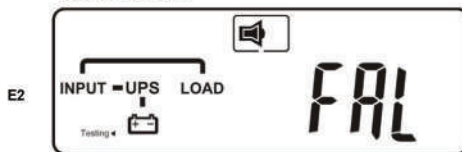

"Fail" in self-test

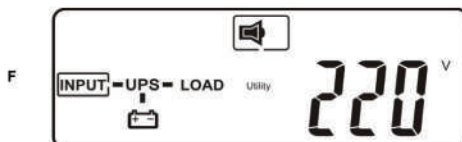

"220 VAC" in Utility Input

If the self-test fails the LCD display will change from figure D to figure E2.

Then an error If the self-test fails the LCD display will change from figure D to figure E2. Then an error code or error status will appear on the screen.

Your start-up operation of the UPS is complete now. Make sure the UPS is plugged into the wall receptacle for charging at least 8 hours and the batteries are fully charged before connecting the device to be protected.

### 1.6.2 Start-up in battery mode (cold start)

Make sure the UPS has at least one set (20 pcs) of 12V/7AH batteries.

Push the UPS On Switch (ⓘ) once for approximately 5 seconds to awaken the UPS. The buzzer will sound twice. The LCD display will change from figure A to figure G for approximately 15 seconds.

Press the UPS On Switch (ⓘ) again for about three seconds until the LCD display changes from figure G to figure H. Then the UPS will be in self-test mode. The UPS may offer energy to the output in a minute, and the LCD displays figure I. In case of failure in pushing the UPS On Switch for 15 seconds, the UPS will automatically turn off. You must then repeat steps 1.6.2

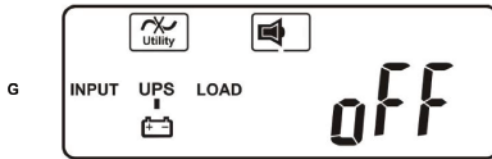

“Off”, which means the UPS pre-start was successful

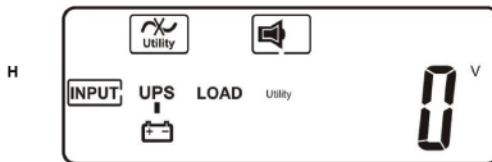

Utility input is “0” and Utility Abnormal.

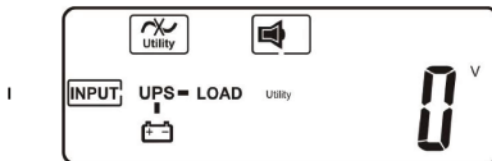

### 1.6.3 Check measured values and figures detected by the UPS

If you would like to check the measured values and figures detected by the UPS use the scroll up (↑) and scroll down (↓) keys. When you scroll down the LCD will display figure C (Voltage from Utility Input) → figure I1 (Voltage from Bypass Input) → figure J (Frequency from Utility Input) → figure K (Frequency from Bypass Input) → figure L (UPS Output Voltage) → figure M (UPS Output Frequency) → figure N (UPS Output Load %) → figure O (UPS Battery Voltage) → figure P (UPS Inner Temperature).

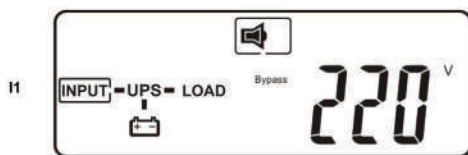

Voltage comes from Bypass Input.

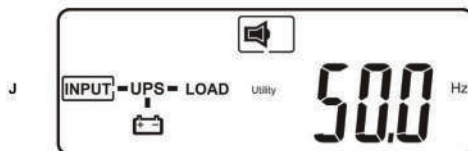

Frequency of Utility Input

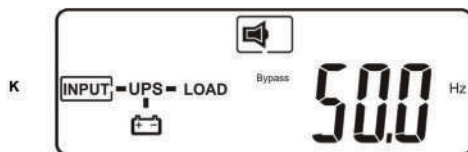

Frequency of Bypass Input

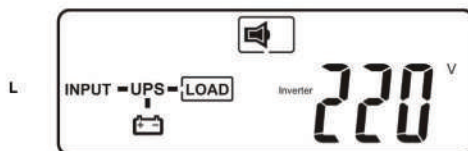

UPS output voltage

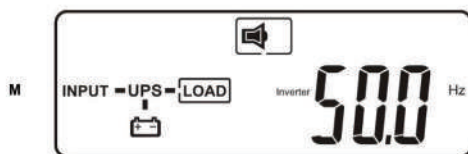

UPS output frequency

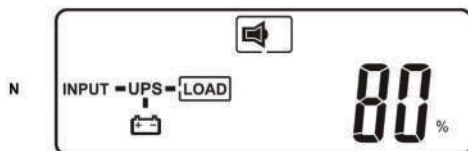

UPS output load level (%)

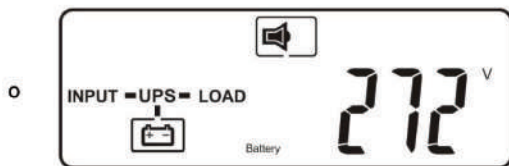

Battery voltage

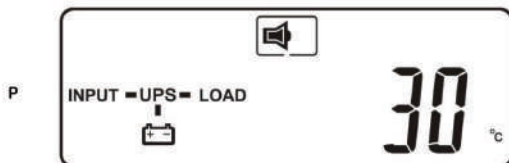

UPS inner temperature

#### 1.6.4 UPS default data and special function execution

After the UPS completely starts up, press the  key to change the LCD display to figure Q1.



Buzzer "On"



Buzzer "Off"

Press the  key to scroll through the UPS settings. The LCD will display in sequence figure Q1 (buzzer) → figure R1 (Self-test) → figure S1 (Bypass Voltage Windows) → figure T (Output Frequency Synchronization Window) → figure U (Inverter Output Voltage) → figure V1 (UPS Operation Mode) → figure W (Output Voltage Micro Tune Value) → figure X (UPS Id) → figure Y (Parallel function status).



Self-test is not "On".

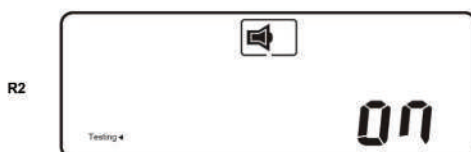

Self-test is "On".

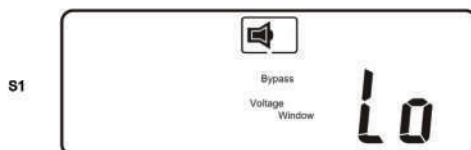

Bypass Voltage is adjusted to narrow range

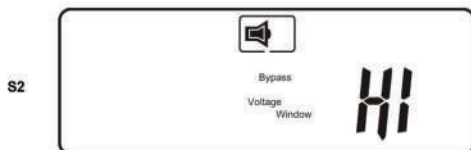

Bypass Voltage is adjusted to wide range.

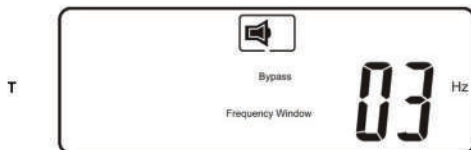

Frequency Window is +/-3 Hz.

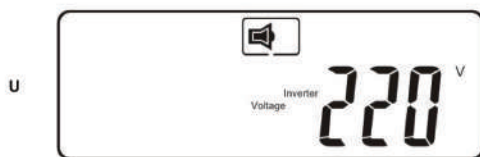

Inverter output voltage



The UPS is operating in "normal mode".

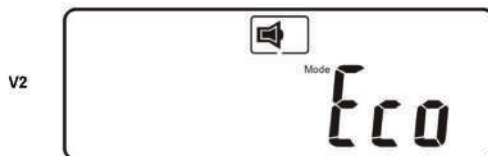

The UPS is operating in "Eco mode".

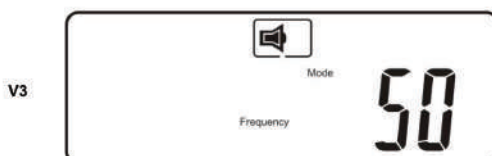

The UPS is operating in "CVCF 50 Hz mode".

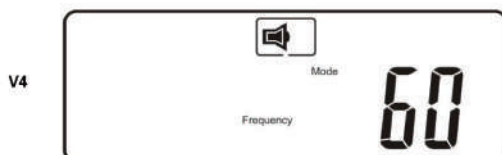

The UPS is operating in "CVCF 60 Hz mode".

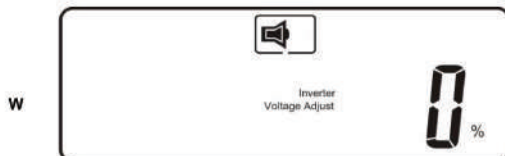

Output Voltage Adjustment (-3% to 3%)

X

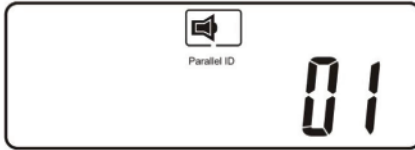

UPS position in parallel mode

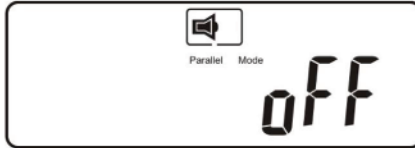

Y



The parallel function is disabled.

Press the scroll up  key to execute special functions. The functions include buzzer ON (as in figure Q1), buzzer OFF (as in figure Q2, Alarm silence for UPS Warning), and self-test OFF (as in figure R1) or self-test ON (as in figure R2). The UPS will execute the battery test for ten seconds. If the self-test is successful it will display figure E1; otherwise, it will display figure E2 and an error message at the same time.)

### 1.6.5 UPS Default settings and their alternatives

Make sure the UPS is not "On". Press the On  and scroll down  keys simultaneously for approximately three seconds. The buzzer will sound twice, and the LCD will display figure Q1, indicating that the UPS is in setting mode.

To scroll through the options refer to section 1.5.4.2

Except for Buzzer (figures Q1 and Q2) and Self-test (figures R1 and R2) all of the other default settings may be changed by pressing the scroll up  key.

Figures S1 and S2 indicate the bypass input acceptable window. It can be 184-260 VAC or 195-260 VAC.

Figure T indicates the bypass frequency window of the Inverter Output. The acceptable setting values are  $\pm 3$  Hz and  $\pm 1$  Hz.



Figure U indicates the acceptable Inverter Output Voltage. Possible values are 200, 208, 220, 230, or 240 VAC.

Figures V1, V2, V3 and V4 indicate the operation modes of the UPS. Possible values are Online, Eco (Economical) mode, fixed 50 Hz Output, and fixed 60 Hz Output.

Figure W indicates the adjustment of the Inverter Output, which may be set to 0%, +1%, -1%, +2%, -2%, +3%, or -3%.

Figure X indicates the position of the UPS when the UPS is in Parallel mode. Possible positions are 1, 2, 3, and 4. The position must be 1 if the UPS is not in Parallel mode.

Figure Y indicates the parallel function status. "P 01" indicates that the parallel function is disabled, and "P 02" indicates that the parallel function is enabled.

After changing settings you must scroll to the "End" screen (figure Z) and then press the enter  key to save all of your changes. Then the LCD will display figure AA to indicate completion of the setting changes. To cancel your changes rather than save them press and hold the "OFF" key  for five seconds. The LCD displays figure AA directly, which indicates that your changes were canceled.



\* Press the Enter key to save changes.



The UPS is locked.

Turn Off the Utility Input breaker.  
Your setting changes are now complete.

### 1.6.6 Troubleshooting when the UPS is Off Due to unknown reasons

If there is a serious abnormal condition the UPS will lock itself in the "OFF" position as shown in figure AA, and an "abnormal" message will appear on the LCD.

After three seconds all messages will be locked except Bypass messages (LED  and LCD .

If the Utility is abnormal after the UPS is locked the LED  will be

extinguished and the LCD  will appear on the LCD.

To release the UPS lock proceed as follows:

Check the recorded error messages.

Check the error messages in chapter OLM74005 to help troubleshoot the problem. For further help consult your local distributor.

Press the Off  key for five seconds. A buzzer will sound twice.

Turn Off the Utility Input breaker.

Even if the UPS lock problem is solved now, consult with your local distributor to make sure that the error condition is resolved.

### 1.6.7 Shut Off

Press the Off  key for five seconds. The Inverter output will be turned off, and the output load will be supplied by the Bypass loop. The LCD will display figure B.

Turn Off the Utility and Bypass Input breakers.

The UPS is now turned off completely.

### 1.6.8 Maintenance bypass mode

Maintenance Bypass Mode is for UPS maintenance only. Only authorized technicians are allowed to perform the following procedures. If there is any damage during unauthorized execution of these procedures your warranty will be void immediately.

Press the Off  key for approximately five seconds. The LCD will display figure B, and the UPS output will be in bypass mode.

Remove the cover of the CAM Switch (Maintenance Bypass Switch), then turn on the CAM

Switch to "Bypass" mode. In the upper right-hand corner of the LCD a  sign will appear.

Turn off the UPS Utility breaker as well as the Bypass Input Breaker. You may proceed with UPS maintenance now.

When you are done with UPS maintenance put the UPS back into normal working mode as explained in section 1.6. Then return the CAM switch to "INV" mode, replace the cover, and repeat sections 1.6.1. The UPS will switch back to inverter mode.

If you skip section Maintenance Bypass mode (section 1.6.8) the UPS will alert for ten seconds to warn that the procedure is abnormal and may damage the UPS due to uncertain utility status.

The UPS will switch back to Inverter mode immediately if you turn.

# TROUBLESHOOTING GUIDE OF BORRI LEONARDO UPS

---

<b>Index</b>	<b>Page</b>
<b>1 Troubleshooting guide .....</b>	<b>32</b>
<b>1.1 Troubleshooting .....</b>	<b>32</b>

# 1 Troubleshooting guide

## 1.1 Troubleshooting

If the UPS malfunctions during operation please check that all lines are connected properly and that the utility specifications are correct. Then check the table below for solutions. Should the problem persist please contact your local dealer for assistance.

Situation	Check Items	Solution
red Fault LED	<p>Check the error code shown on the LCD.</p> <ol style="list-style-type: none"> <li>Er05, Low ◀ &amp; Fault ◀</li> <li>Er06, Er10, Er12, Er28 &amp; </li> <li>EPO</li> <li>Er11, Er33</li> <li>Er14</li> <li>Er15</li> <li>Er16, Er27</li> <li>Er21</li> <li>Er24</li> <li>other error code</li> </ol>	<ol style="list-style-type: none"> <li>Check for proper battery connection, then recharge the batteries for 8 hours to see whether the UPS provides backup power normally; otherwise, consult your local distributor right away.</li> <li>If CB3 is tripped, turn off the UPS completely and keep the CAM switch at position INV before pressing CB3. Then remove some uncritical load at the UPS output end. If there is any damage to the insulation of the AC power cord, please replace it with a new one.</li> <li>Remove the short circuit at the EPO terminal.</li> <li>Remove any objects blocking the ventilation holes.</li> <li>Check that the cooling fans on the rear panel are working normally.</li> <li>Make sure the UPS is operated normally. If it is in CVCF mode you must turn off and turn on the UPS again.</li> <li>All of the parameters except ID Number in a parallel UPS must be the same. Please refer to section (1.5.5 OF CHAPTER Installation and operating) to set them again.</li> <li>Disconnect and reconnect the RJ45 connector or set a UPS with ID=1.</li> <li>When the UPS is in CVCF mode it is prohibited from having bypass input. You must turn off the UPS and bypass input and then restart the UPS.</li> <li>Consult your local distributor for help.</li> </ol>
UPS fails to offer battery backup or its backup power time is shorter than calculated.		If the backup power time is still too short after 8 hours of charging please contact your local distributor for battery replacement.
UPS locks itself and can not be turned off.		Refer to chapter OML74006 section Installation and operating to troubleshoot the problem; otherwise, consult your local distributor for help.

## COMMUNICATION SOFTWARE OF BORRI LEONARDO UPS

<b>Index</b>	<b>Page</b>
<b>1 Communication software .....</b>	<b>34</b>
<b>1.1 Hardware setup .....</b>	<b>34</b>
<b>1.2 Software installation .....</b>	<b>34</b>

## 1 Communication software

### 1.1 Hardware setup

1. Decide whether to use RS-232 communication or USB communication.
2. Connect a male RS-232 connector or a USB cable\* to the UPS communication port.  
Connect the female RS-232 connector or the other end of the USB cable to the computer.

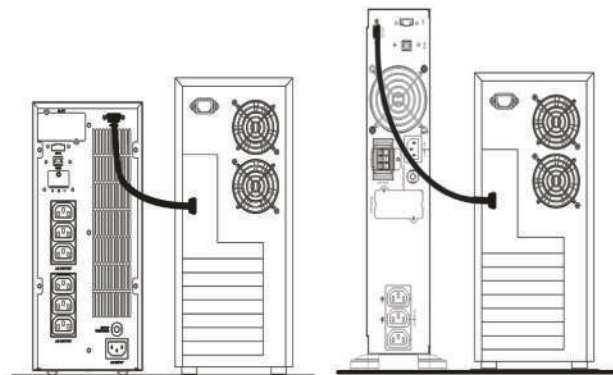

**\*Note: RS-232 and USB cables are optional.**

### 1.2 Software installation

Please downloading to [www.borri.it](http://www.borri.it)

## OPTIONAL BATTERY PACK OF BORRI LEONARDO UPS

<b>Index</b>	<b>Page</b>
1 Important safety instructions.....	36
2 Introduction to the Rear Panel.....	37
2.1 Rear Panel descriptions.....	37
3 Installation and operation.....	37
3.1 Unpacking.....	37
4 External battery box specification.....	40
4.1 External battery box specification LEONARDO T.....	40
4.2 External battery box specification LEONARDO RT.....	40

## 1 Important safety instructions

### **SAVE THESE INSTRUCTIONS**

This manual contains important instructions that should be followed during installation and maintenance of the battery bank and batteries.

#### **An Important Notice**

- This battery bank is connected to an UPS. There will be over 240 DC voltage at the output terminals if the UPS or DC breaker is turned on.
- Do not try to repair the unit yourself, contact your local supplier or your warranty will be void.
- To eliminate any overheating of the battery bank, keep all ventilation openings free from obstruction and do not place any foreign objects on top of the battery bank. Keep the battery bank 20 cm away from the wall.
- Make sure the battery bank is installed within the proper environment as specified. (0-40C and 30-90% non-condensing humidity)
- Do not install the battery bank under direct sunlight. Your warranty will be void if the batteries fail due to overheating.
- This battery bank is designed for indoor use only.
- This battery bank is not designed for use in dusty, corrosive and salty environment .
- The warranty for this battery bank will be void if water or other liquid is spilt or poured directly onto the battery bank. Similarly we do not warrant any damage to the battery bank if foreign objects are deliberately or accidentally inserted into the battery bank enclosure.
- The battery will discharge naturally if the system is unused for a period of time.
- It should be recharged every 2-3 months if unused. If this is not done, then the warranty will be null and void. During normal operation, the batteries will be automatically remained in charged condition.
- Servicing of Batteries Should be Performed or Supervised by Trained Personnel with Knowledge of Batteries and the Required Precautions
- When Replacing Batteries, Replace With the Same Quantity, Type & Capacity.
- CAUTION – Do Not Dispose of Battery or Batteries in an open fire. The Battery May Explode.
- CAUTION – Do not open or mutilate the batteries. The electrolyte from the batteries is toxic and harmful to the skin and eyes.
- CAUTION – Risk of Electric Shock – Battery Circuit is not isolated from AC, hazardous Voltage may exist between battery terminals and ground. Test before touching with bare hands.
- CAUTION – A Battery can present a Risk of Electrical Shock and High Short Circuit Current. The Following Precaution Should be Observed When Working on Batteries:
  - A. Remove watches, rings, or other metal objects.
  - B. Use tools with insulated handles.
  - C. Wear rubber gloves and boots.
  - D. Do not lay tools or metal parts on top of batteries.
  - E. Disconnect charging source prior to connecting or disconnecting battery terminals.

## 2 Introduction to the Rear Panel

### 2.1 Rear Panel descriptions

LEONARDO T 6/10 kVA

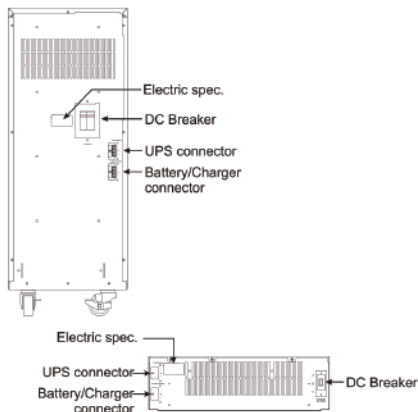

LEONARDO RT 6/10 kVA

## 3 Installation and operation

Note: The packing condition and the external outlook of the unit should be inspected carefully before installation. Retain the packing material for future use.

### 3.1 Unpacking

**Take the battery bank out of the PE foam.**

**Remove the packing materials.**

Note: The battery bank module is approx. 120 kgs, be cautious when unpacking and lifting the unit to avoid injury.

Standard Package includes:

*DC connect cable ↖ C1 or C2 ↗.*

*A pair of kits to fix DC connect cable ↖ A4 or C1 ↗.*

*The casters cover kits A1~A3 and S1 for Tower model.*

*The Rack/Tower kits A1~A3, B1~B3, C1~C3 and S1~S4 for RT model.*

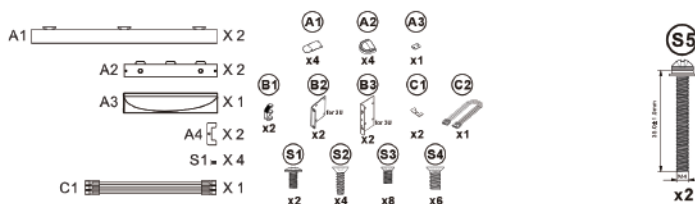

### Selecting Installation Position

It is necessary to select a proper environment to install the unit, in order to minimize the possibility of damage to the battery bank and extend the life of the batteries. Please follow the instructions below:

**Keep at least 20cm(8 inches) clearance from the rear panel of the battery bank from the wall or other obstructions.**

**Do not block the air-flow to the ventilation openings of the unit.**

**Please ensure the installation site environmental conditions are in accordance with the battery bank working specifications to avoid overheat and excessive moisture.**

**Do not place the battery bank in a dusty or corrosive environment or near any flammable objects.**

**This battery bank is not designed for outdoor use.**

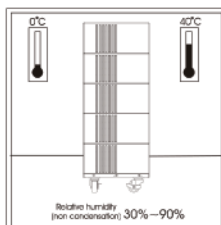
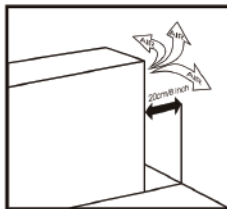

### Installation of Casters Cover and Rack/Tower kits

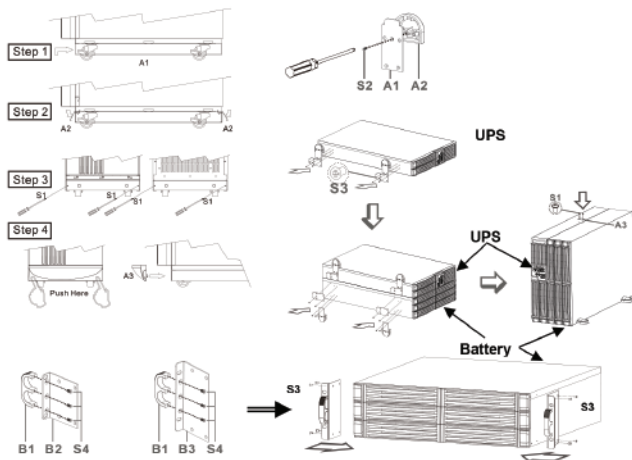

**Installation Instructions**

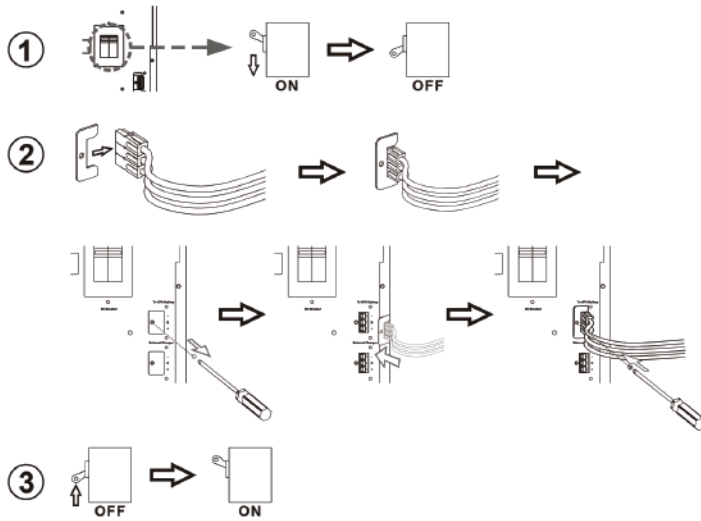

**LEONARDO T 6/10 kVA**

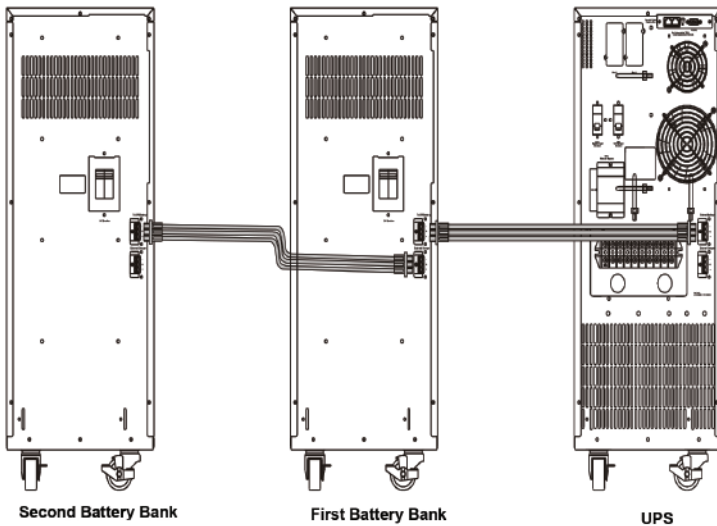

**Storage Instruction**

For extended storage through moderate climate (-15 to +30 °C / +5 to +86 °F), the batteries should be charged for 12 hours every 6 months by plugging the UPS power cord into the wall

receptacle. Repeat this every 3 months under high temperature (+30 to +45°C/+86 to +113 °F) environment.

## 4 External battery box specification

### 4.1 External battery box specification LEONARDO T

UPS	6/10 kVA
Battery Bank Code	MUPSBATT0004
Nominal System Voltage	240 VDC
Battery Quantity	60
Battery Type	9 Ah
Max. Charge Current	47 A
Connector color	Red ( + ), Black ( - ), Green(Gnd)
Dimensions W x D x H (mm)	
Unit	290 x 631 x 748
Shipping	468 x 810 x 961
Weight (kg)	
Unit	194
Shipping	212

### 4.2 External battery box specification LEONARDO RT

UPS	6/10 kVA
Battery Bank Code	MUPSBATT0005
Nominal System Voltage	240 VDC
Battery Quantity	20
Battery Type	9 Ah
Max. Charge Current	47 A
Connector color	Red ( + ), Black ( - ), Green(Gnd)
Dimensions W x D x H (mm)	
Unit	440 x 680 x 132
Shipping	560 x 804 x 272
Weight (kg)	
Unit	65.2
Shipping	68.2

## **OPTIONAL COMMUNICATIONS CARDS OF BORRI LEONARDO UPS**

<b>Index</b>	<b>Page</b>
<b>1 Optional communication cards.....</b>	<b>42</b>
<b>1.1 Second RS-232 card.....</b>	<b>42</b>
<b>1.2 USB card .....</b>	<b>42</b>
<b>1.3 Dry contact card .....</b>	<b>43</b>
<b>1.4 SNMP cards .....</b>	<b>44</b>
<b>1.4.1 Megatec SNMP card.....</b>	<b>44</b>
<b>1.4.2 USB .....</b>	<b>44</b>
<b>1.4.3 EPO .....</b>	<b>44</b>

## 1 Optional communication cards

### 1.1 Second RS-232 card



CN1 is for RS-232 DB9.

For interface settings and pin assignments please refer to Chapter OML74010.

Installation Position: Optional Slot.

### 1.2 USB card

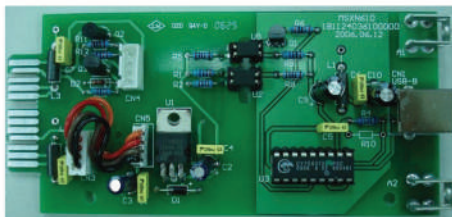

CN1 is for USB.

For the communication protocol definition please refer to Chapter OML74010.

Installation Position: Optional Slot.

### 1.3 Dry contact card

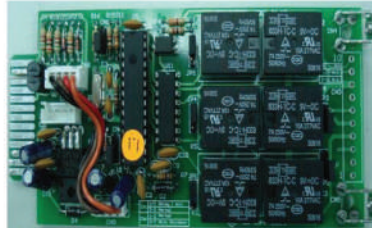

Pin assignments of 10-Pin terminal:

1	2	3	4	4	5	6	7	8	9	10
---	---	---	---	---	---	---	---	---	---	----

- 1 → UPS in Bypass mode (Bypass)
- 2 → Utility Normal (normally closed contact)
- 3 → Utility Normal (normally open contact)
- 4 → Inverter On
- 5 → Battery Low
- 6 → Battery Bad or Abnormal
- 7 → UPS Alarm
- 8 → Common
- 9 → Shutdown UPS positive (+) signal
- 10 → Shutdown UPS negative (-) signal

The shutdown function will be activated after +6-25 VDC is applied between pin 9 and pin 10 for 5 seconds.

The capacity of each relay contact is 40 VDC/25 mA.

Installation Position: Optional Slot.

Flexible signal output for N.C. (Normally Closed) or N.O. (Normally Open) contact by shorting pins 1-2 or pins 2-3 from JP1-5.

The shutdown function will be enabled 1 minute after blackout occurs if pins 1-2 of both CN1 and CN6 are shorted. Otherwise the shutdown function can be enabled only by pins 9-10 of CN3 if pins 2-3 of both CN1 and CN6 are shorted.

## 1.4 SNMP cards

### 1.4.1 Megatec SNMP card



For installation please refer to the user's manual that came with the card.  
Installation Position: Optional slot on rear panel

### 1.4.2 USB

The USB communication protocol definition is as below.

1. Complies with USB version 1.0, 1.5 Mbps.
2. Complies with USB HID version 1.0.
3. Pin Assignments:

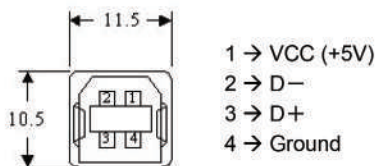

### 1.4.3 EPO

Pin Assignments:

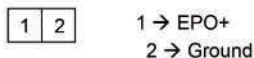

To enable the EPO function short pins 1 and 2.



---

# TECHNICAL SPECIFICATIONS OF BORRI LEONARDO UPS

<b>Index</b>	<b>Page</b>
<b>1</b> <b>Technical specifications.....</b>	<b>46</b>

**1 Technical specifications**

<b>BORRI LEONARDO UPS</b>	<b>T *</b>	<b>T *</b>	<b>RT **</b>	<b>RT ***</b>	<b>RT **</b>
Rating (kVA)	6	10	6	6	10
Nominal power (kW)	5.4	9	5.4	5.4	9
UPS dimensions HxWxD (mm)	748x290x645	881x290x645	88x440x680	176x440x680	132x440x680
UPS weight (kg)	86 Kg	96 Kg	24 Kg	52 Kg	26 Kg
<b>Input</b>					
Nominal voltage (V)	230 Vca single phase				
Voltage range	195 / 260Vca				
Frequency and range	45 / 65 Hz				
Power factor	0,99				
Current distortion (THDi)	<6%				
<b>Output</b>					
Nominal voltage (V)	230 Vca single phase				
Frequency	50/60 Hz				
Power factor	0,7 – 0,9				
<b>Connectivity and function extensions</b>					
Front panel	Display LCD, LED signaling, function keys				
Communication	Standard: RS232, USB, EPO Opzional: RS485, dry contact card, SNMP card, second RS232 card Compatible platforms: Microsoft Windows, Linux, Mac				
<b>Environmental</b>					
Operating temperature range	0°C + +40°C				
Relative Humidity	0-90%				
<b>Standards and certifications</b>					
Marking	CE				
Safety	IEC EN 62040-1				
EMC	IEC EN 62040-2				
Quality assurance, Environment, Health and Safety	ISO9001:2008, ISO 14001:2004, BS OHSAS 18001:2007				

**\*Tower****\*\*Rack Tower****\*\*\*Compact model with internal batteries**

---

---

---

---

---

---

